

Westell® Boxer® BXM2019-4HE3 & BXM2019-4HE3G Outdoor Cabinets with a 24VDC/-48VDC 400W Heat Exchanger

CONTENTS	PAGE #
1. GENERAL	1
2. FEATURES	3
3. INSTALLATION	7
4. MAINTENANCE	15
5. SERVICE & REPAIRS	15
6. CUSTOMER & TECHNICAL SERVICES	18
7. WARRANTY & RETURNS	18
8. SPECIFICATIONS	19
9. APPENDIX A - Product Views	21

1. GENERAL

1.1 Document Purpose

This document provides general, installation, and specification information for the Westell® Boxer® BXM2019-4HE3 and BXM2019-4HE3G Outdoor Cabinets with Heat Exchangers (-4HE3 model shown in Figure 1). This product is designed to provide Network equipment protection in outdoor environments while providing a quick and easy customer hand-off. The intended audience for this document is engineering, operations, and installation personnel of MSO, Telco, and utility companies. See Table 4 for product ordering information and available options, as well as information on the companion but optional battery box or skirt that can be mounted under the Boxer cabinet.

- NOTE -

Hereafter, either model may be referred to as the “Boxer-20” or “cabinet.” Where differences between models apply, “-4HE3” or “-4HE3G” will be specified.

- NES/OSHA NOTE -

All applicable NES/OSHA requirements shall be followed during installation of this product.

1.2 Document Status

Whenever this practice is updated, the reason will be stated in this paragraph. Revision B adds the -4HE3G model to this document, adds several “G” models to Table 4, adds the NES/OSHA note above, adds the GR-487 Issue 4 compliant bullet list feature in Paragraph 1.5 (for the -4HE3G model), and updates Figure 4 and Figure 7 to show the pin-in-hex screw locks for the -4HE3G model.

1.3 Product Purpose and Description

Boxer-20 is a compact, actively-cooled, NEMA 4 (and GR-487 for the -4HE3G model) outdoor cabinet that can house and protect a wide range of electronic equipment. Up to 20 vertical RUs (35”) of 19-inch wide internal rack space is available to house Network equipment such as (but not limited to) multiplexers,

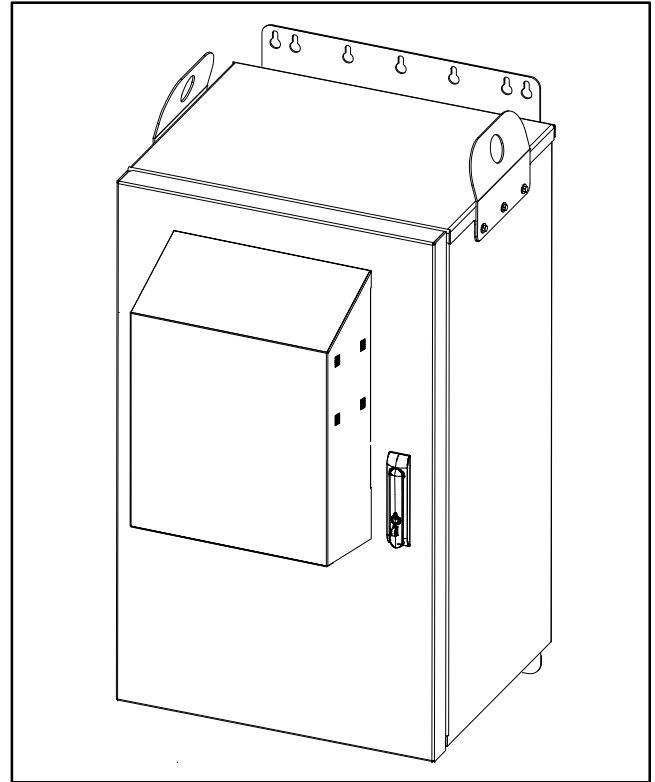

Figure 1. Isometric Closed View of Boxer-20 Cabinet

copper bonding solutions, Ethernet switches and media converters, xDSL boxes, and DS3 hand-offs. Protectively mounted on the Boxer front door, separate from the interior rack space, is a heat exchanger and fan unit.

Boxer-20 supports rapid equipment installation and wiring through the use of adjustable and removable 19” rack channels. An access panel is located at the rear of Boxer-20 to allow easy access to the rear of the installed equipment. To ensure easy access for input/output cables, Boxer-20 includes ample room below the rack space as well as various sized conduit knock-outs.

1.4 Product Mounting

The Boxer-20 cabinet is typically mounted outdoors, above ground. Optional mounting kits are available to mount the cabinet on an H-frame, a wall, a round pole (from 8” to 20” in diameter) or a square pedestal or post (minimum 8” wide). Concrete pad mounting is supported when used with an optional Boxer battery box or skirt. All mounting hardware must be capable of supporting the weight of the Boxer-20 cabinet plus the weight of any equipment mounted in it. The Boxer-20 cabinet is typically located at the customer premises but can be located anywhere a compact, weather-tight, outdoor cabinet is required.

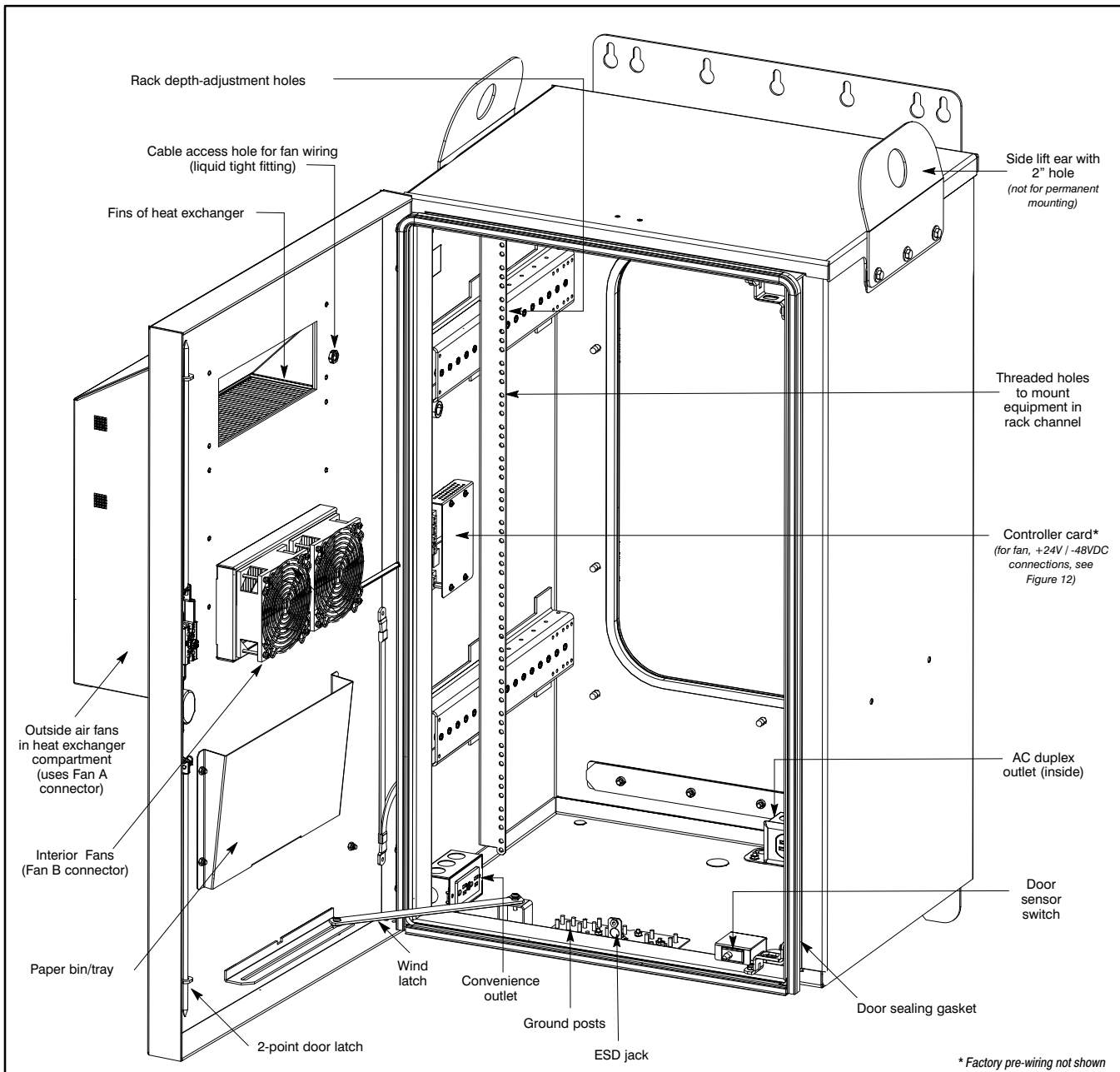

Figure 2. Isometric Open View of Boxer-20 Cabinet

1.5 Product Features

Each Boxer-20 cabinet comes fully assembled, pre-wired, tested, and ready for field-provided customer equipment installation, and includes the following features and capabilities.

- NEMA 4 compliant (both models)
- GR-487 Issue 4 compliant (BXM2019-4HE3G model)
- Actively-cooled with heat exchanger
 - Dissipates up to 400 watts
- Field-replaceable door-mounted fans
- -48VDC or +24VDC powered
- Low noise level
- Temperature-controlled heat exchanger fans
- Fan test button (on controller card)
- Compact size (24" W x 40" H x 28" D, approx.)
- Weather-tight cabinet
- Removable/adjustable rack channels

- Rear-access panel
- Interior area provides 20 RUs of 19" rack mounting space
- Ample space for tie-downs and cable management
- Numerous ground/bond posts on interior ground plate
- Knock-outs at cabinet bottom accept a variety of cable, conduit, and connector sizes and types
- Door security via:
 - 2-point latch (top and bottom)
 - Cup-washer screw (requires can wrench, -4HE3 model)
 - Pin-in-hex screw (pin-in-hex wrench provided, -4HE3G)
 - a hole/hasp for a padlock
- Interior sliding wind latch
- Door open alarm/sensor switch
- Full-width heavy-duty mounting brackets allow H-frame, wall, or post mounting
- Pole or pedestal mounting via optional pole-mount kit
- Pad mount using the optional battery box or skirt (optional pad mount kit available)
- Convenient, heavy-duty, side-mounted, lift brackets
- Optional battery backup box available (knock-out hole patterns match in both units)
- Optional side-mount customer demarcation cabinet
- AC GFI and AC duplex outlets
- Bagged parts: AC cable, vent cap, cable ties
- Light-weight aluminum construction (0.125" thick wall) with powder-coat finish

2. FEATURES

This section describes the exterior and interior features of the Westell® Boxer® outdoor cabinet in more detail. Refer to Figure 2 through Figure 10 as needed while reading this section.

2.1 Exterior Features

The features located outside the large main cabinet are described hereunder. See Paragraph 2.2 for the interior features.

2.1.1 Construction and Materials

The Boxer-20 cabinet is designed to be weather-tight for above-ground applications. As such, the powder-coat painted aluminum cabinet withstands many harsh weather conditions such as rain, snow, and sleet.

2.1.2 Cabinet

The cabinet utilizes an "in-the-door" heat exchanger design. Cabinet cooling is accomplished through the front-door-mounted heat exchanger, fans, and vents. Security is provided via a 2-point latch, a tamper-proof screw lock and a padlock hasp. Side-wall lift ears (Paragraph 2.1.2.6) are provided for temporary installation lift-assistance. The bottom floor of the

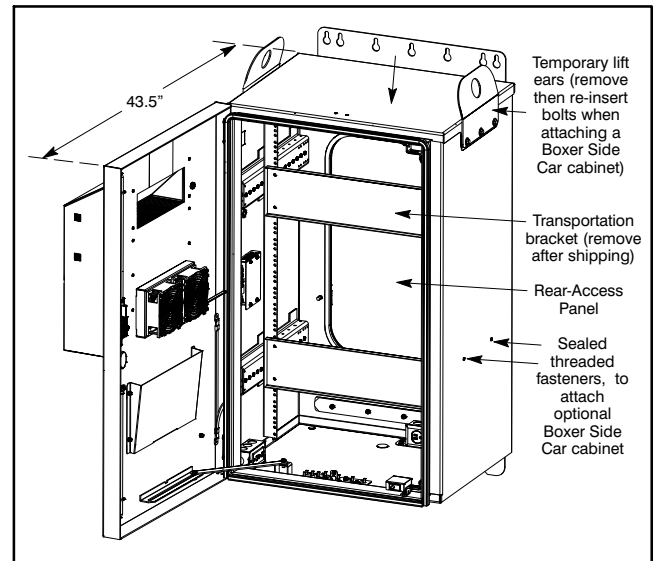

Figure 3. Boxer-20 Depth, Door Open

main cabinet contains numerous, differently-sized, intact knock-outs (Paragraph 2.1.2.7) to accommodate a variety of cable, fitting, or conduit sizes and types.

2.1.2.1 Large Cabinet Door

A full-size locking door provides ample technician and equipment access to the interior of the cabinet and also helps protect the cabinet from tampering and vandalism. When the cabinet is mounted and the door is open, the clearance or distance from the back of the cabinet to the outer edge of the open door is approximately 43.5" (as shown in Figure 3). The cabinet's cooling system is based in the door, with screened holes, a heat exchanger and fans mounted in the door. At the inside bottom of the door, near the hinge, a wind-latch, shown in Figure 2, protects the door (and technician) from possible wind damage. The wind latch restricts the door's swing-out angle to a safe but functional opening (95 degrees). In the closed position, the inside perimeter of the door mates with a gasket installed around the outer perimeter of the cabinet's door opening. When the door is closed and tightened, the door and gasket provide a weather-tight seal to protect all equipment installed inside the cabinet. The door sensor is described in Paragraph 2.2.2.

2.1.2.2 Door Handle, Door Locks and Panel Lock(s)

Built into the 2-point latching door handle is a padlock hasp and a tamper-proof lock. The lock (Figure 4) is loosened and tightened with a can wrench or 216 tool (for the -4HE3 model) or a pin-in-hex wrench (for the -4HE3G model, wrench provided). In addition to providing security, when fully-tightened, this cup-screw lock helps to seal the cabinet and protect the interior environment from outside elements or contaminants by compressing the door and panel against their gasket(s). Additional security is offered for the door via a hasp in the handle that accepts a field-provided lock or padlock. Once the locks are open, lift the bottom of the handle and rotate the handle counter-clockwise to release the 2-point latch. **When closing and locking the door, the door must be pushed fully closed before actuating the swing handle, or damage to the locking mechanism may result.**

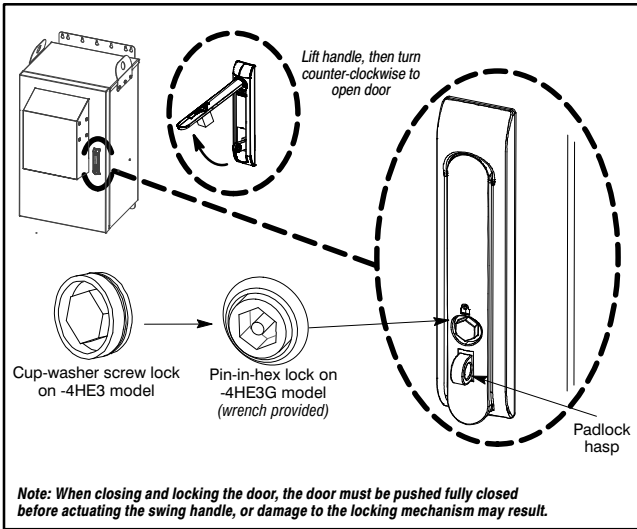

Figure 4. Door Handle with Dual Locks

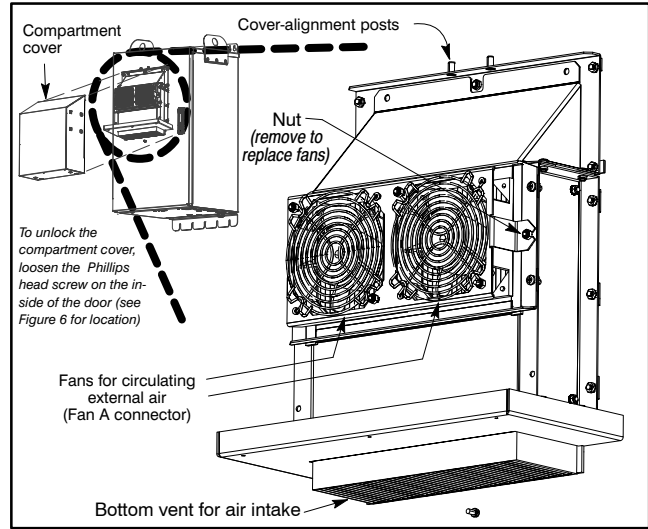

Figure 5. Heat Exchanger Compartment, Cover Off

2.1.2.3 Heat Exchanger Compartment

The cabinet's cooling system is based in the door, in a heat exchanger compartment (see Figure 5). The compartment has a secure cover, vents, a heat exchanger, and fans. To access the heat exchanger compartment, loosen the Phillips screw that secures it, located near the center inside surface of the door (under the internal fans, shown in Figure 6), then lift the compartment cover up off the cover-alignment posts at the top of the compartment (see Figure 5).

2.1.2.4 Rear-Access Panel (Detachable)

The rear-access panel (Figure 7) can be removed for convenient access to the rear of equipment mounted inside Boxer-20. The purpose of the access panel is to facilitate equipment access, cabling, and servicing. The panel is secured with ten

tamper-proof screws (hex-nut-in-cup type for the -4HE3 model and pin-in-hex type for the -4HE3G model). The panel can be removed with either a 216 tool or can wrench (for the -4HE3 model) or with a special hex wrench (provided with the -4HE3G model). With the panel removed, the access hole measures approximately 17" wide by 23.5" high (see Figure 6).

2.1.2.5 Mounting Brackets

Full-width mounting brackets are attached at the back of the Boxer-20 cabinet, one at the top and one at the bottom. The top bracket has seven mounting holes in it (two of which are spaced 16" apart for stud wall mounting) and the bottom bracket has five slots, for easy slide-in installation. Use approved wall-mounting fasteners with a diameter of up to 3/8". The vertical distance between the top and bottom bracket mounting holes is 42.7". *The mounting hardware and the mounting surface must be of*

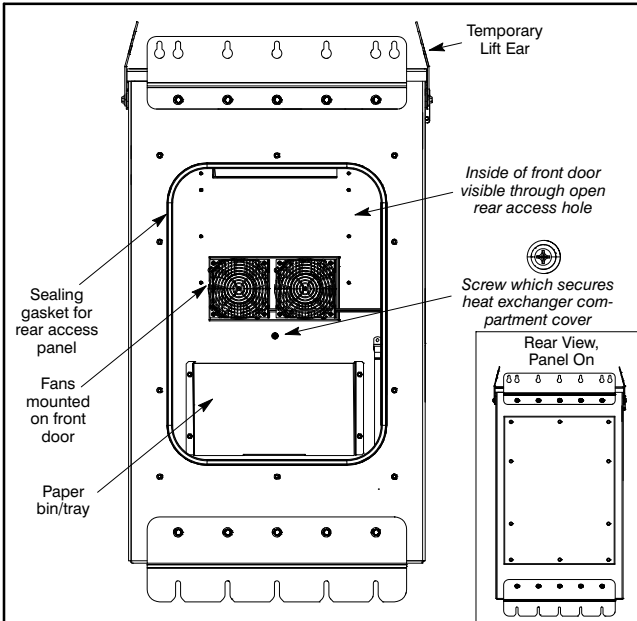

Figure 6. Boxer-20 Rear View, Rear Access Panel Removed

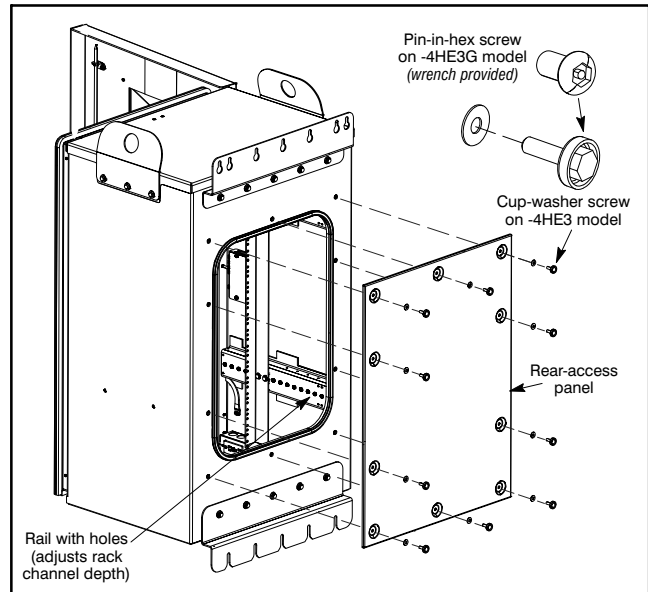

Figure 7. Rear Isometric View of Boxer-20, Showing Rear Access Panel Removed

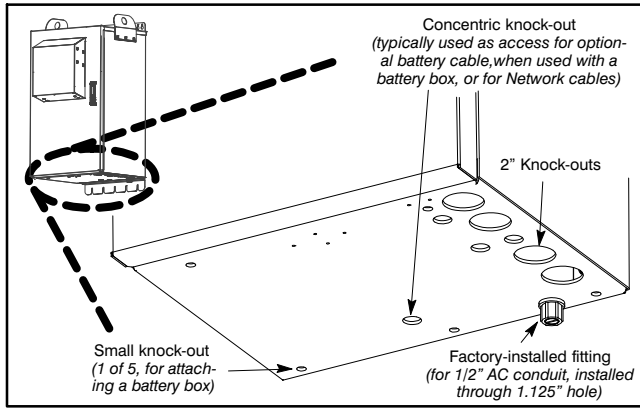

Figure 8. Bottom Isometric View of Cabinet

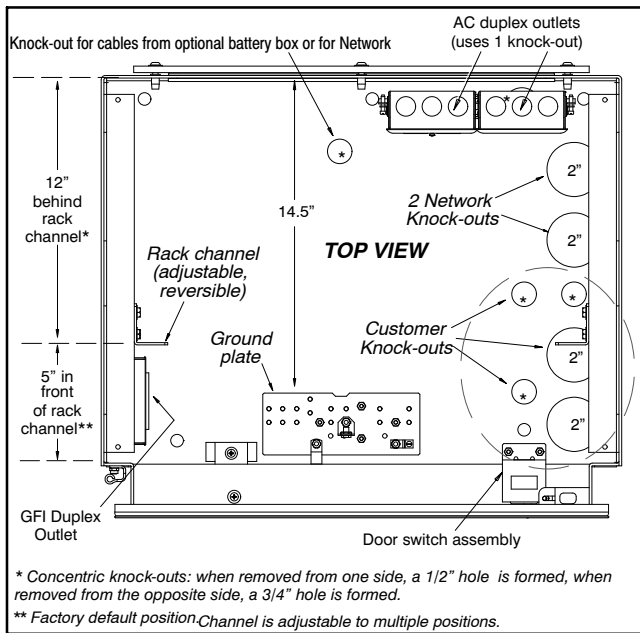

Figure 9. "See-Through" Top View of Cabinet, Door Off

sufficient strength, quality and size to support the cabinet plus all equipment to be mounted in it.

2.1.2.6 Side Lift Ears

The Boxer-20 cabinet is equipped with two removable external lift ears or brackets, one on each side, attached at the top of the cabinet (see Figure 3). These lift ears can be used to lift the cabinet using lift equipment, for mounting purposes. Each ear has a hole with a 2" diameter, to accommodate various cable, strap, or hook sizes. Always use two straps of equal lengths, one for each lift ear, when using this method to lift the cabinet. Remove the ears if mounting with a Boxer side car (use the same hardware). **Do not use these lift ears for permanent mounting.**

2.1.2.7 Bottom Floor Knock-outs

Multiple knock-outs are provided on the floor of the cabinet. One near the center rear of the floor is for cable ingress and egress for an optional battery cabinet that can be mounted below the Boxer-20 cabinet (or for Network cables). Provided on the

right side of the cabinet floor are multiple intact knock-outs, for easy Network and Customer cable access. The front-most three are typically for customer cable access, and the rear-most knock-outs are typically for Network cable access. The knock-out sizes and quantities are shown in Table 1 and Figure 9. A "concentric" knock-out is provided for both Customer and Network access: depending upon which direction the knock-out is removed, either a 1/2" or 3/4" hole will be produced. Do not remove a knock-out unless it is absolutely necessary to do so for cable ingress and egress, and use either tight-fitting rubber grommets or liquid-tight fittings, or other proper and approved knock-out hole sealants, to assure the best internal air quality and weather-resistance. Always use proper and company-approved tools to remove knock-outs. There are five, small, 0.575" diameter knock-outs in the floor of the Boxer-20 cabinet where an optional battery box attaches to the cabinet (hole patterns of both units match).

- KNOCK-OUT REMOVAL NOTE -

Always remove knock-outs where holes are desired before mounting the cabinet or the optional battery box, regardless of the type of knock-out and the order of the mounting steps.

Function	Quantity	Description
Customer	2	2.5" knock-out for 2" conduit
	3	1.125" concentric knock-out, can be used for 1/2" or 3/4" conduit.
Network	2	2.5" knock-out for 2" conduit
	1	1.125" concentric knock-out, can be used for 1/2" or 3/4" conduit.
Battery Box	5	0.575" diameter knock-outs, matches hole pattern in optional battery box

Table 1. Knock-out Sizes and Quantities

2.1.2.8 AC Conduit Fitting

A 1/2" AC conduit fitting is provided on the exterior bottom surface of the cabinet (see Figure 8) through a knock-out hole near the back right corner, to facilitate conduit attachment or power cable access. The fitting is connected to an AC outlet box immediately above it inside the cabinet.

2.2 Interior Features

The interior cabinet features are described hereunder.

2.2.1 Internal 19" Rack Channels

Two removable/adjustable rack channels inside the cabinet provide 20-RU-high 19" relay rack mounting for equipment that is to be mounted in the cabinet. Each adjustable channel is factory-installed so approximately 5" of equipment space is available from the inside of the closed front door to the channel (for up to a 5" equipment projection), and approximately 12" of equipment space is available behind the channel to the rear cabinet wall. The channels can be moved forward or backward the entire depth of the cabinet, as needed, if more equipment depth is needed at either the front or back of the channel. Multiple holes are provided for multiple channel positions. Each rack channel has predrilled holes, with standard hole spacings (either 1", 1.75", or 2" rack hole patterns), to mount customer-supplied equipment in the cabinet. Network equipment up to 20 Rack Units (20 RUs = 35") high can be mounted on the internal rack inside the cabinet, either as a single piece or multiple pieces of equipment.

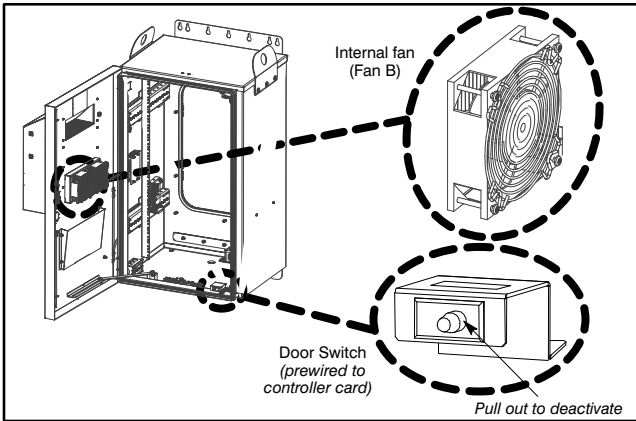

Figure 10. Door Sensor Switch & Internal Fan Locations

- LEFT CHANNEL NOTE -

Access to the controller card may be limited if one of the front-most channel mounting positions is chosen for the left channel.

2.2.2 Door Sensor Switch

A door sensor switch is located at the bottom right corner of the cabinet door opening (Figure 10). This switch is factory-prewired to the Controller Card for door alarm reporting purposes. To temporarily disable the sensor, pull out the cylindrical door switch actuator until it clicks. To re-activate the sensor, either gently push the actuator back in until a click is heard, or simply close the cabinet door.

2.2.3 Cooling System

The Boxer-20 cabinet features an active heat-exchange system that compensates for the effects of internal equipment heat and external solar and temperature loading inside the cabinet. The heat exchanger fans are temperature activated. The fans turn on when the interior of the cabinet reaches 35° C (95° F) and turn off when the internal cabinet temperature cools to 25° C (77° F). At the core of the heat exchange system are numerous aluminum fins (best seen in Figure 2) on each “side” of a sealed divider wall within the heat exchanger. The dual air-path exchanger uses one set of fans (shown in Figure 11) to blow cool outside air past the “exterior air side” fins of the heat exchanger and to direct the heated air out the screened holes on the sides

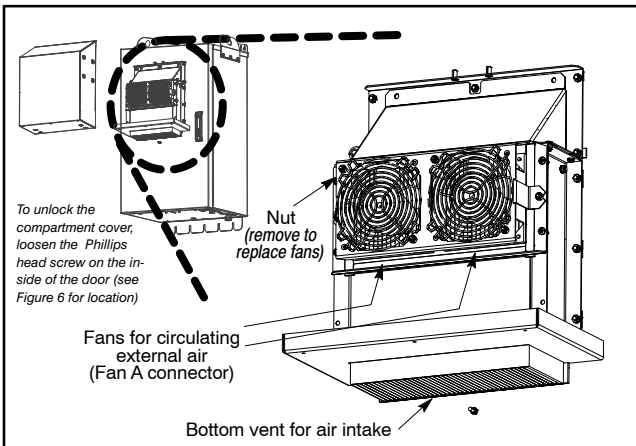

Figure 11. Heat Exchanger Compartment, Cover Off

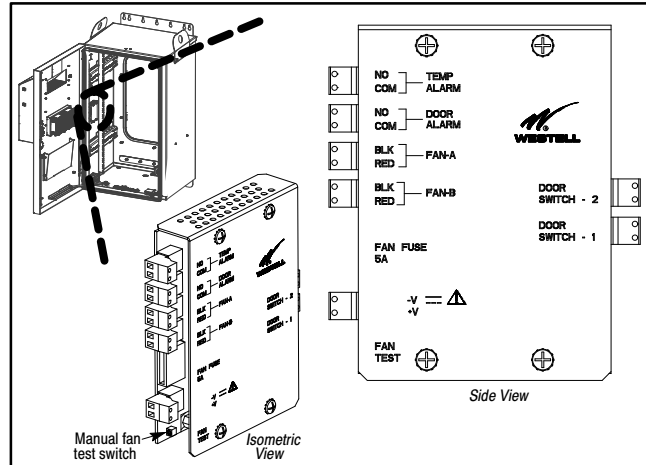

Figure 12. Controller Card (Showing Euro-connectors)

of the fan cover. Conversely, a second set of fans (shown in Figure 2 and Figure 10) circulates warm inside air down past the “interior air side” fins of the heat exchanger and blows cooled air back through the main cabinet compartment. Both sets of fans are field-replaceable (see Table 4 for part numbers).

2.2.4 Internal-Air Fans (“FAN B” Connector)

Two, factory-installed, temperature-controlled fans (see Figure 10) to circulate warm interior air down through the heat exchanger and back into the cabinet are located on the inside of the cabinet door. These fans are factory-wired to the “FAN-B” connector on the controller card mounted on the left side wall of the cabinet, and are powered from either a field-provided +24VDC power source or a -48VDC power source.

2.2.5 External-Air Fans (“FAN A” Connector)

Two, factory-installed, temperature-controlled fans (shown in Figure 11) to circulate cooler exterior air up through the heat exchanger are located under the cover of the heat exchanger compartment. These fans are factory-wired to the “FAN-A” connector on the controller card mounted on the left side wall of the cabinet, and are powered from either a field-provided +24VDC power source or a -48VDC power source. To access or view the fans, loosen the Phillips screw near the inside center of the door, then lift off the cover off its two posts.

2.2.6 Controller Card

This section and Table 2 describe the features of the controller card. Internal wiring has been factory-wired. See Paragraph 3.8 and 3.9 to perform external connections (installer power, temperature, and alarm wiring and connections) to the controller card.

Boxer-20 includes a factory-wired controller card located on the inside left wall of the cabinet (Figure 12). The card includes connections for power and for the fans, temperature alarm, door alarm, a fan test button and a 5A fan fuse. Internal wiring has been factory-wired. External wiring to the power source and alarm monitoring equipment is done using “Euro-connector” snap-in terminal blocks which can be disconnected from the controller card, and later re-inserted for quick and easy connections. Table 2 lists all of the connectors and positions on the controller card. **The only installer connections needed are the TEMP ALARM, DOOR ALARM, and power connections (-V and**

+V). To make these connections to the Euro-connectors, pull-off the Euro-connector, loosen the screws inside the set-screw holes, strip approximately 3/8" off the end of each wire, insert wire(s) into hole(s), tighten screws, and push-on the Euro-connector (see Paragraph 3.8 and 3.9 for more installation details).

Connector Name	# of Positions	Position Name	Description
Left Side of Controller Card			
TEMP ALARM	2	NO	Normally Open. <i>(Installer connects to field-provided equipment.)</i>
		COM	Common. <i>(Installer connects to field-provided equipment.)</i>
DOOR ALARM	2	NO	Normally open. <i>(Installer connects to field-provided equipment.)</i>
		COM	Common. <i>(Installer connects to field-provided equipment.)</i>
FAN – A* <i>(2 External Air Fans)</i>	2	BLK	– voltage. Factory connected to Fan A.
		RED	+ voltage. Factory connected to Fan A.
FAN – B* <i>(2 Internal Air Fans)</i>	2	BLK	– voltage. Factory connected to Fan B.
		RED	+ voltage. Factory connected to Fan B.
FAN TEST	button	FAN TEST	Momentary push-button to test fan operation
+24V Power Operation Only Power Connections	2	BLK -V	System Ground <i>(Installer connects to field-provided DC power.)</i>
		RED +V	Apply +24V <i>(Installer connects to field-provided DC power.)</i>
-48V Power Operation Only Power Connections	2	BLK -V	Apply -48V <i>(Installer connects to field-provided DC power.)</i>
		RED +V	System Ground <i>(Installer connects to field-provided DC power.)</i>
Right Side of Controller Card			
DOOR SWITCH 1	2	DOOR SWITCH-1	Not used.
DOOR ALARM SWITCH 2	2	DOOR SWITCH-2	Door open alarm. Factory wired.

*Two fans are wired to each set of terminals.
Shaded rows indicate installer connections (TEMP ALARM, DOOR ALARM, and Power)

Table 2. Controller Card Connectors – Front Access

Connectors and Features on the Controller Card

- **TEMP ALARM Euro-Connector.** A Normally Open Temperature Alarm thermostat contact closes when the internal cabinet temperature exceeds 65° C and will remain on until the temperature drops below 55° C. For temperature alarm connections, connect alarm wiring from the field-provided alarm equipment to the 2-position Euro-connector at the top left of the controller card.

- **DOOR ALARM Euro-Connector.** A Normally Open (NO) Door Alarm contact closes when the door is opened. For door alarm connections, connect wiring from the field-provided alarm equipment to the 2-position Euro-connector labelled DOOR ALARM at the top left of the controller card.
- **Fan A and Fan B Euro-Connectors.** The internal temperature-controlled fans are factory-wired to the controller card at the FAN-A and FAN-B Euro-connectors (FAN-A = external fans, Fan-B = internal fans). The fans require a -48VDC, 1.75A *or* a +24V, 3.5A power source to be wired to the power Euro-connector of the controller card.
- **5A Fan Fuse.** A field-replaceable 5A fuse for proper fan operation is provided and accessible near the left bottom corner of the controller card. Remove this fuse whenever performing fan maintenance or replacing the fans.
- **-V and +V power Euro-Connector.** The Euro connector labelled -V and +V is prewired to a 48" red and black cable wire stub. For +24V power applications, connect the red wire to the +24V source and connect the black wire to ground. For -48V power applications, connect the black wire to the -48V source and the red wire to ground.
- **Fan Test Button.** A momentary fan test button is provided in the lower left corner of the controller card. Use this button for fan testing purposes.
- **Door Switch 1 Euro-Connector.** A door switch connector labelled DOOR SWITCH - 1 is not used.
- **Door Switch 2 Euro-Connector.** A door switch connector labelled DOOR SWITCH - 2 is provided at the right side of the controller card. This connector is factory-prewired to the door alarm/sensor switch for door open alarming. The door switch is field-replaceable.

2.2.7 AC Duplex & GFI Outlets for Installed Equipment

In the bottom-right rear corner of the cabinet are two AC duplex outlets (with a 1/2" fitting below one on the cabinet exterior surface), for powering any customer-supplied AC-powered equipment mounted in the cabinet. When an external AC power source is connected to these outlets, AC power also can be provided to the GFI convenience outlet in the lower-left front corner of the cabinet (to facilitate the installer's test equipment powering), by installing the provided AC 3-wire cable (see Figure 21).

2.2.8 Grounding and Bonding Center

Boxer-20's grounding and bonding center is located on the bottom interior surface of the cabinet (Figure 13), close to the front door. A ground plate is provided that contains eight sets of ground posts and one copper ground lug, for cable, equipment and chassis/earth ground. Bond equipment/cables to the ground posts per company practice, and connect a #6 AWG chassis or earth ground wire to the ground lug. An Electro-Static Discharge (ESD) wrist-strap jack is also located on the ground plate. Ground lug hardware should be tightened to 20 inch-pounds.

3. INSTALLATION

Use and follow local codes and company practices to install the Westell® Boxer® cabinet. If none exist, use the instructions contained herein. Installation consists of:

- inspecting the unit for damages that may have incurred during shipping,
- following proper safety precautions,
- reviewing pre-mounting considerations, such as selecting the mounting type and location, and preparing the mounting site,
- gathering all tools, materials, and equipment,
- removing any knock-outs where access holes are required,
- mounting the cabinet,
- making ground and all power connections,
- powering up the cabinet (system power-up),
- mounting any customer-supplied equipment inside the cabinet,
- making communication cable connections,
- making any desired alarm connections,
- optioning the installed equipment and placing it in service, and
- performing cabinet housekeeping, and closing and locking the cabinet.

The following paragraphs provide detailed instructions for performing these procedures.

3.1 Inspecting the Equipment

- INSPECTION NOTE -

Visually inspect the unit for damages prior to installation. If the equipment has been damaged in transit, immediately report the extent of the damage to the transportation company and to Westell (see Part 6 for telephone number).

- DESICCANT NOTE -

To prevent condensation during shipment and storage, Westell includes a desiccant pack within the Boxer-20 cabinet. Once the electronic equipment is installed and turned-up, the internal power dissipation reduces the likelihood of condensation within the cabinet. However, follow company practices for desiccant maintenance procedures to prevent internal condensation.

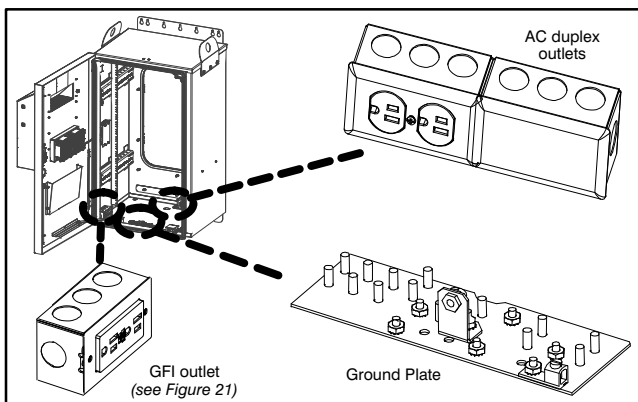

Figure 13. Ground Plate & AC Duplex Outlet Locations

3.2 Following Proper Safety Precautions

The cabinet should be installed only by authorized and trained personnel. Always exercise caution and follow all safety precautions.

Important Safety Instructions (Please Save)

When using your telephone/telecommunications equipment, follow basic safety instructions to reduce the risk of fire, electric shock, and injury to person(s), including the following:

- Read and understand all instructions.
- Follow all warnings and instructions marked on product.
- Do not place this product on an unstable cart, stand or table: the product may fall, causing serious damage to product.
- Slots and openings in the cabinet are provided for ventilation. To protect it from overheating, these openings must not be blocked or covered. This product should never be placed near or over a radiator or heat register. This product should not be placed in a built-in installation unless proper ventilation is provided.
- This product should be operated only from the type of power source indicated on the marking label.
- Never push objects of any kind into this product through cabinet slots as they may touch dangerous voltage points or short out parts that could result in the risk of fire or electrical shock. Never spill liquids of any kind on the product.



CAUTION - STATIC-SENSITIVE



This product contains static-sensitive components! Proper electrostatic discharge procedures must be followed to maintain personal and equipment safety. Do not store units near magnetic, electromagnetic or electrostatic fields. Always store or ship units in the original static-protective packaging from Westell. Use anti-static mats when working on units.

- PRECAUTIONARY STATEMENT -

Never install telephone wiring during a lightning storm.

Never install telephone jacks in wet locations unless the jack is specifically designed for wet locations.

Never touch uninsulated telephone wires or terminals unless the telephone line has been disconnected at the network interface.

Use caution when installing or modifying telephone lines.

3.3 Selecting and Preparing the Mounting Type and Site (Pre-Mounting Considerations)

Mount the cabinet in a location with an adequate earth ground and power access, with unobstructed cabinet access, and which insures the best lighting, ventilation, heat dissipation, and equipment access. Verify sufficient space exists to allow the opening of the left-hinged large door, to access and mount the cabinet, to mount and access the optional battery box if it will be mounted below it, and to adequately access, prepare, and dress all cables. Adequate horizontal and vertical space should be left between any multiple installations to allow for cabinet opening, equipment access, and cable routings and preparations. Follow company practice for the proper distance from the cable entry point or from upstream or downstream equipment.

3.4 Gathering all Tools and Equipment

The following tools and supplies (not provided) are required to mount the Boxer-20 cabinet.

Door Opening/Locking Tools

- 7/16" can wrench or 216 tool (-4HE3) or provided pin-in-hex wrench (-4HE3G)
- Padlock (optional)

Knock-Out Removal Tools

- Hammer
- Punch
- Pliers

Cabinet Mounting Tools, Equipment, and Hardware

- Tape measure
- Marking utensil (to mark mounting hole locations)
- Level (optional)
- Power or hand drill with assorted bits, plus long bits or drill bit extensions if pole mounting
- Socket driver and sockets, or wrenches
- Wall- or pole-mounting hardware, such as 3/8" diameter wood-type lag screws or bolts
- H-frame mounting hardware (for H-frame mounting)
- Optional pole-mount kit (for pole mounting)
- Outdoor site preparation tools
- Safety gloves and glasses (optional)
- Power hoist or lifting equipment and cables (optional)
- Assorted screwdrivers
- Appropriate ground wire and equipment

Cable Preparation Tools and Equipment

- Cable opening and preparation tools
- Proper lengths and types of communications cables
- Proper lengths and types of power cables and fittings
- Cable management supplies (ties, clips, markers, etc.)
- Power installation and testing equipment
- ESD protection

3.5 Removing the Knock-outs

Knock-outs should be removed prior to mounting the cabinet. See Figure 9 or Table 1 for knock-out sizes, quantities, and locations, and follow the steps below to remove the knock-outs.

1. **Open the cabinet door.** If knock-outs will need to be removed, using a 216 tool or can wrench (-4HE3), or the provided pin-in-hex wrench (provided with the -4HE3G), open the large front door of the Boxer-20 cabinet to access the knock-outs.
2. **Remove knock-out(s).** Prior to mounting the cabinet, per company practice, remove as many appropriately-sized knock-outs at the bottom of the cabinet as needed for the specific application (consider ground, power, and communication cable access needs, venting, and whether optionally mounting a battery box with the cabinet).
3. **Install rubber grommets or conduit fittings.** Install either a heavy-duty rubber grommet or the conduit fitting of choice (liquid-tight recommended) in each selected knock-out hole. If an optional vent is desired, the provided vent cap can be installed in one of the smaller knock-outs.

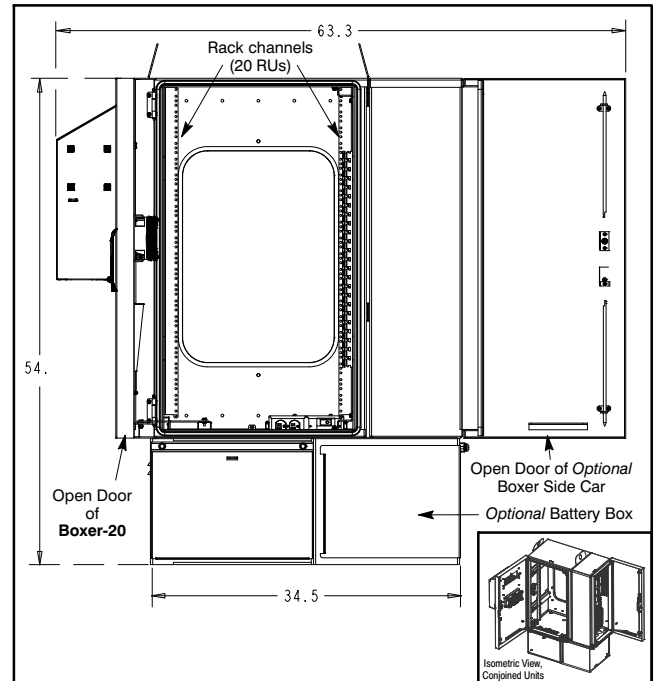

Figure 14. Open Boxer-20 Front View (and Side Car, Mounted On Battery Box)

4. **Close the cabinet door.** Once the knock-outs are removed, lock the door using the 216 tool, can wrench or pin-in-hex wrench, to minimize possible product damage and personal injury.

3.6 Mounting the Cabinet

The Boxer-20 cabinet is typically mounted outdoors, above ground, on an H-frame, a wall, a concrete pad, or a pole. Optional mounting kits are available to support pole (from 8" to 20" in diameter), wall, and H-frame mounting. Concrete pad mounting is typically performed in conjunction with the optional Boxer battery box. An optional pad mount template kit is available for easy and convenient cement anchor placement. All mounting hardware (not provided) must be capable of supporting the weight of the Boxer-20 cabinet plus the weight of any equipment mounted in it. For convenience, lift hooks or ears are provided for temporary lifting purposes (do not use lift ears from which to hang the cabinet in permanent installations). Run all cables to the mounting location, perform any trenching, trench cable placements, and backfilling prior to the cabinet mounting, and clear the installation area of any debris, vegetation, and unneeded equipment or obstacles.

- KNOCK-OUT REMOVAL NOTE -

Always remove knock-outs where holes are desired before mounting cabinet or securing the battery box, regardless of the knock-out type and regardless of the order of the mounting steps. All knock-outs should be knocked out from the inside of the cabinet, except for the small 0.575" knock-outs (which are to be knocked out from the outside of the cabinet) and except for the concentric knock-out (from either direction, per hole size).

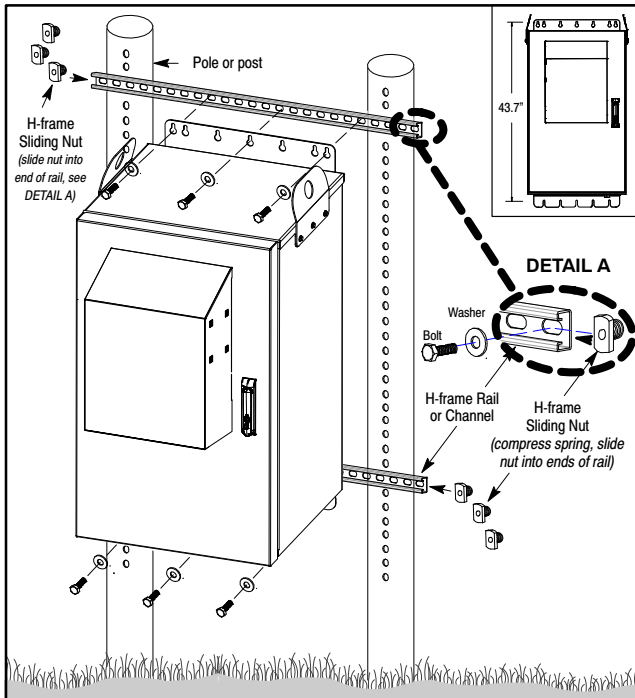

Figure 15. H-Frame Mounting

- WEIGHT NOTE -

The Boxer-20 cabinet weighs 110 pounds. The weight of the internal equipment installed in the Boxer-20 should not exceed 130 pounds. The mounting surface, structure, and hardware must be able to support the combined weight (240 pounds).

3.6.1 Mounting on an H-Frame

Follow company practice or the steps below to mount the Boxer-20 cabinet on an H-frame. See Figure 15 for an H-frame mounting drawing. If the installation includes the battery box, attach the battery box and the H-Frame mounting kit to the cabinet prior to mounting to the H-Frame.

1. **Determine exact mounting location in H-frame.** Select and mark the exact horizontal and vertical final mounting location within the H-frame. The spacing between the top and bottom H-frame horizontal-rail mounting holes should be 42.7" (on centers). Westell recommends a height of 30" from the ground. In addition to leaving a comfortable installer working height, leave adequate space under Boxer-20 for cable access, as well as in front of the cabinet to allow the door to open, and at the sides in the event of any multiple installations.
2. **Remove knock-outs.** See the steps in Paragraph 3.5 (*Removing the Knock-outs*) to remove the knock-outs where any cable access holes (or holes for mounting the optional battery box) are desired. Note that if a Boxer "Side Car" cabinet is being installed with the Boxer-20, remove the small, blind, threaded receptacles on the Boxer-20's right side wall to accommodate the side car's mounting bolts..

3. **Prepare the H-frame mounting hardware.** Bring the appropriate rail nuts (to secure the cabinet to the H-frame) to the installation site. The mounting hardware must be able to support the weight of the cabinet plus the weight of the added internal equipment. Insert at least three rail nuts into each rail (compress the spring on the nuts as needed) and place them at the desired locations.
4. **Lift cabinet.** Lift the cabinet to the mounting height. If using lift equipment, use two cables or straps of equal length, one connected to each lift ear, for a balanced symmetrical lift. The lift ears are provided at the top of the cabinet, one at each side wall, and each lift ear has a 2" hole in it.
5. **Attach cabinet to H-frame rails.** Align the holes in the cabinet's top mounting bracket with the holes in the inserted rail nuts in the H-frame rails, then insert and install an appropriate bolt through each set of aligned holes. Westell recommends a minimum of 3 mounting bolts per mounting flange (top and bottom). Tighten hardware appropriately. Repeat for the bottom mounting bracket and H-frame rail. Verify the cabinet is in the proper horizontal position, make any needed adjustments, then securely tighten all mounting hardware.
6. **Test installation firmness.** Test the installation by attempting to move the cabinet. Correct any looseness, if detected. Tighten all bolts again.
7. **Determine next step.** If ground, power, and communications cables and internal equipment will not be connected and mounted at this time, proceed to the next step to finalize the cabinet installation. If ground, power, and communications cables and internal equipment will be connected, mounted, and powered-up at this time, skip the next step and proceed to Paragraphs 3.7 through Paragraph 3.16 for those procedures.
8. **Close up cabinet and clean the site.** Close the Boxer-20 door, and lock it using a can wrench or 216 tool (-4HE3) or the provided pin-in-hex wrench (-4HE3G) and an optional padlock. Pick up any tools and materials at the installation site, and clean the site of any trash or debris.

3.6.2 Mounting on a Wall

Follow company practices or the steps below to mount the Boxer-20 cabinet to an approved wall (Figure 16). The approved wall and hardware used must be able to support the combined weight of the cabinet and the equipment mounted inside the cabinet. Westell recommends a minimum cabinet installation height of 30" from the ground.

1. **Find best wall position.** Locate the best mounting position for the cabinet on the wall. Verify this location meets all cabinet spacing requirements and company practices.
2. **Remove knock-outs.** See the steps in Paragraph 3.5 (*Removing the Knock-outs*) to remove the knock-outs where any cable access holes (or holes for mounting the optional battery box) are desired. Note that if a Boxer Side Car also will be mounted with the Boxer-20 cabinet, the knock-outs on the right side wall of the Boxer-20 should be removed, as well.
3. **Prepare the mounting hardware.** Bring the appropriate wall-mounting hardware to the installation site. The hard-

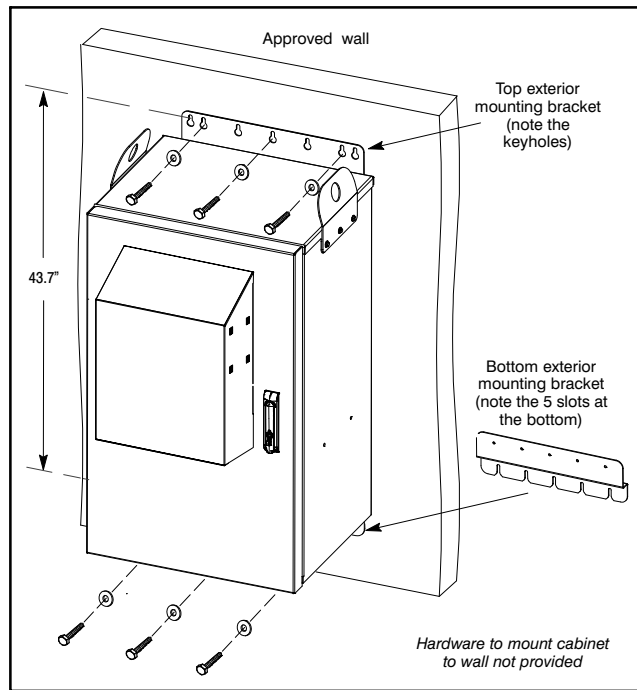

Figure 16. Wall Mounting

ware must be capable of supporting the weight of the cabinet plus the weight of the added internal equipment. Use a minimum of 6 mounting fasteners (such as lag bolts).

4. **Determine mounting height and mark top hole locations.** Measure and mark the top mounting hole locations on the wall, in a straight level line. This can be done by lifting and leveling the cabinet then marking the mounting hole locations, or without lifting and using the equipment as a template. The inside keyholes are 4" apart on centers, and two of the holes are 16" apart on centers, to facilitate mounting on standard walls with studs 16" apart on centers. The vertical distance between the holes in the installed top and bottom mounting brackets (when attached to the cabinet) is 43.7". Westell recommends a minimum of 3 mounting bolts in each mounting bracket. In addition to allowing for a comfortable installer working height (leave about 30" under the cabinet), leave adequate space under Boxer-20 for cable access, as stated in Paragraph 3.3, as well as in front of the mounting to allow the door to open and at the sides in the event of any multiple installations. With a marking utensil, mark the top mounting holes to be drilled, in a level horizontal line, at the desired wall height.
5. **Drill top mounting holes.** Drill appropriately-sized pilot holes, slightly smaller than the width and depth of the mounting bolts, screws or fasteners, at the marked locations. *Do not drill the holes too large.*
6. **Partially install bolts.** Partially install the bolts until only 1/2" remains.
7. **Lift cabinet, and align mounting holes.** Lift the cabinet to the protruding bolts, align the top mounting bracket's key-

holes with the bolts, then hang the cabinet from the bolts. If using lift equipment, use two cables or straps of equal length, one connected to each lift ear, for a balanced symmetrical lift. The lift ears are provided at the top of the cabinet, one at each side wall, and each lift ear has a 2" hole in it.

8. **Fully install the top mounting bolts.** Verify the cabinet is level. Finish driving the top mounting bolts until they are snug and the cabinet is flush and tight against the wall. Manually test the bolt tightness to verify the bolts will support the cabinet weight before the next step. Correct any level or mounting bolt discrepancies.
9. **Drill bottom mounting holes.** Drill appropriately-sized pilot holes, slightly smaller than the width and depth of the bolts, for the lower mounting bracket. Use a minimum of three bolts. *Do not drill the holes too large.*
10. **Install bottom mounting bolts.** Insert and drive all bottom bolts completely in to their final seated position. Finish the installation by verifying all bolts are firm and snug.
11. **Determine next step, or close up cabinet and clean the site.** Repeat Steps 6-8 of Paragraph 3.6.1 to determine the next step or finish the physical cabinet installation.

3.6.3 Mounting on a Pole or Post

Order the optional A90-BXA-PM02 pole mount kit (shown in Figure 17 and listed in Table 4) for details and instructions on pole-mounting the Boxer-20 cabinet. See Figure 18 for a brief installation procedure.

3.6.4 Mounting on a Concrete Pad

The Boxer-20 cabinet can be mounted on a concrete pad, typically with an optional Boxer battery box (and "side car"). To facilitate the concrete anchor bolt placement, order and use the optional A90-BXA19-PT1 pad mount kit (listed in Table 4) for details on pad-mounting the Boxer-20 cabinet.

- NOTE -

Always follow local safety precautions and standard operating procedures for grounding the equipment when installing, upgrading, repairing or maintaining equipment. Any instructions or information contained herein is subordinate to local codes, operating procedures or practices.

3.7 Making Ground Connections

Eight sets of bond/ground posts, a ground lug, and an ESD jack are provided on a ground plate on the interior floor of the cabinet (see Figure 19). The posts are provided to bond both network and customer equipment or communications cables. An external earth ground rod or wire (#6 AWG) must enter the cabinet and be connected to the ground lug located on the interior ground plate. **Make all ground connections prior to any telecommunications cable connections.**

1. **Locate or establish an external earth ground.** Find or create an external and appropriate earth ground, per company practice and local codes.
2. **Remove a knock-out for the earth ground wire.** Per company practice, determine which cabinet knock-out hole location should be used for earth ground wire entrance (a small forward knock-out is recommended). If not already removed, remove the selected knock-out.

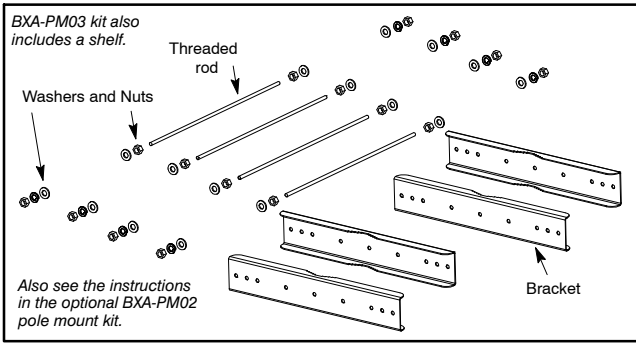

Figure 17. Pole Mount Kit (BXA-PM02) Contents

1. **Attach one bracket and rod of pole-mount kit to top cabinet bracket.** Thread a washer and a nut about 1.5" onto one end of a rod (hereafter called "the short end"). Abut the flat side of a kit bracket against the back of the cabinet's top mounting bracket and align the mounting holes. Insert the short end of the rod through the selected aligned holes. Thread a washer, lock washer, then a nut onto the protruding short end of the rod from the front side of the cabinet's mounting bracket and tighten the nut. Repeat with a second rod at the other side of the top mounting bracket.
2. **Attach lower bracket.** Repeat the step above for the cabinet's bottom mounting bracket and another mounting bracket and rod from the pole-mount kit.
3. **Pre-thread inner nuts for rear brackets.** Thread a nut and washer onto the long end of each rod; stop threading when the nut appears to be about 1/4 of the distance into the pole depth (from the rear).
4. **Lift, level, and secure cabinet to pole.** Lift the cabinet to the desired mounting height, straddle the pole with the protruding rods, press the cabinet and the serrated edge of the attached brackets against the pole, and level the cabinet. Hold the cabinet in place, and from behind the cabinet and pole, hang another kit bracket from the top protruding rods, being careful to select and align the holes correctly (select the same holes that were used for the bracket attached to the cabinet) and also being sure to face the serrated edge of the kit's bracket toward the pole. Thread a washer, lock washer, and a nut onto each rod and alternately tighten each rod's nut firmly against the bracket (so the lengths of the two rods left protruding are equal). When tight, back-thread the nuts previously threaded onto the rod (from Step 3 above) backwards to abut the inside edge of the kit's rear mounting bracket.
5. Repeat above step for the lower, rear, mounting bracket.

Also see the instructions in the optional BXA-PM02 pole mount kit.

Figure 18. Boxer Mounted on Pole with Pole Mount Kit

3. **Install a rubber grommet or liquid-tight fitting.** Install either conduit and an appropriate and liquid-tight fitting or a rubber grommet in the knock-out hole.
4. **Route ground wire through knock-out hole.** Run the approved ground wire through the grommet or conduit to the ground lug.

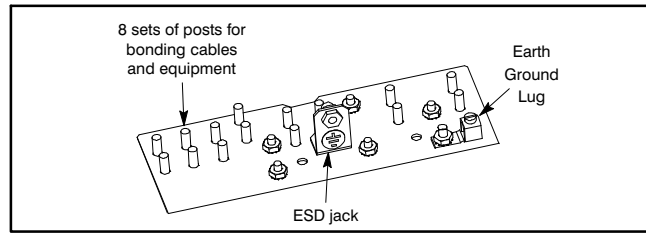

Figure 19. Ground Plate of Boxer-20 Cabinet

5. **Connect earth ground wire.** Connect the earth ground wire to the #6 AWG ground lug on the ground plate, per company practice.
6. **Seal the earth ground entrance hole.** Depending on the type of fitting or grommet used, it may be necessary to seal the ground wire entrance hole, as stated in the note below.

- NOTE -

To improve the integrity of the cable entries seal when rubber grommets are used, a water-proof foam or silicone sealant should be used on the interior side of the cabinet, around the exposed grommet and cable entry.

7. **Ground installed equipment and cables.** As each cable and piece of equipment is mounted inside the cabinet (in the following sections), connect it to a ground lug or post provided on the ground plate, per company practice.
8. **Use ESD ground jack.** Whenever installing equipment or performing system testing or maintenance, use the provided ESD ground jack also provided on the cabinet's interior ground plate.

3.8 Making Fan Power Connections

To power the factory-prewired Boxer cooling fans, an external +24V (3.5A) or -48VDC (1.75A) power source must be connected to the power terminals of the Controller Card mounted on the inside of the cabinet door.

- NOTE -

Ensure that the power source has sufficient power to support the 84 watts required to operate the Boxer-20 fans plus the power required for the telecommunications equipment that is being installed in the cabinet.

Connecting Fan Power

Follow the steps below to connect +24V or -48VDC fan power to the Euro-connector in the Controller Card in the Boxer cabinet. Always follow local codes and company practices, and see Figure 12 and Figure 20 as necessary.

1. **Verify the power source.** Verify the power source is in good working condition.
2. **Remove or disable power.** Disable power at the power source before proceeding.
3. **Remove knock-out for power wires.** Select the best knock-out for power cable ingress and egress, and remove the knock-out per Paragraph 3.5, and prepare any grommet placement and conduit fittings per company practice.
4. **Route wires into cabinet.** Extend and route the DC wires from the power source into the Boxer-20 cabinet through

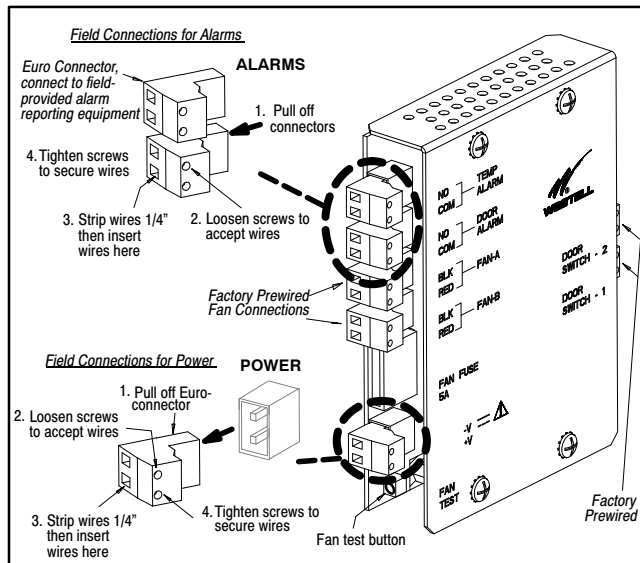

Figure 20. Euro-Connectors for Field-Connections

the knock-out hole. Fish enough wire to reach the Controller Card with adequate slack.

5. **Strip power wires.** Strip off approximately 3/16" from the end of the wires for DC power.
6. **Pull out power Euro-connector.** Remove the 2-position Euro-connector near the bottom left corner of the Controller Card (pull it out, as shown in Figure 20). Loosen the small set screws in the connector to accept the wires.
7. **Connect power wires to loose Euro-connector.** Insert each stripped wire into the proper position (in the rectangular hole, see Figure 20) provided for it in the Euro-connector, holding each wire in place while tightening each screw.
 - **+24VDC operation.**
Connect the negative power wire: Connect the negative power wire to the -V terminal.
Connect the positive power wire: Connect the positive +24VDC power wire to the +V terminal.
 - **-48VDC operation.**
Connect the negative power wire: Connect the -48VDC power wire to the -V terminal.
Connect the positive power wire: Connect the positive power wire to the +V terminal.
8. **Re-install Euro-connector.** After the power wires are properly positioned and secured in the Euro-connector, re-insert the fan power 2-pin Euro-connector back into its receptacle in the lower left corner of the controller card.
9. **Perform wire management.** Perform cable management per company practice.
10. **Proceed to Paragraph 3.11.** Proceed to Paragraph 3.11 for system power-up.

3.9 Optionally Connecting External AC Power

For customer convenience, two internal AC duplex outlet boxes are factory-installed on the interior floor of the cabinet

near the rear right corner (see Figure 21). The right-most one is connected to a standard, electrical, 1/2" conduit connector also factory-installed at the exterior bottom of the cabinet (see Figure 8). To use an external 120 VAC power source to power any equipment that will be installed in the Boxer-20 cabinet, connect 120 VAC to Boxer-20's internal AC duplex outlet via the exterior conduit connector. A co-located pedestal with common access to Boxer-20 shall be used to deliver AC power. The pedestal shall contain a distribution panel, 20 amp circuit breaker, and gapless suppressors. The pedestal shall be capable of accepting 120/240 volts, single phase, and provide hardware for mounting a power meter. However, Boxer-20 must only be supplied with 120 volts.

Follow the steps below to connect an external 120 VAC power source to the Boxer-20 cabinet. *All components in the pedestal must be listed by a Nationally Recognized Testing Laboratory (NRTL), all company practices, local codes, and National Electric Codes must be followed, and only a qualified electrician should perform the AC electrical installation.*

1. **Verify the power source.** Verify the power source is in good working condition.
2. **Remove or disable power.** Disable power at the power source before proceeding (power is re-applied in Paragraph 3.11).
3. **Verify the knock-outs are removed.** Perform the steps in Paragraph 3.5 to remove any appropriate cabinet hole knock-out(s), and to install an appropriate fitting or grommet in the knock-out hole (if needed). Note that Westell has conveniently factory-installed one *external*, electrical, 1/2"-conduit connector (and plug), connected directly to the AC outlet box *inside* the cabinet, for AC applications that use 1/2" conduit.
4. **Install conduit.** Install all required conduit from the power source to the conduit connector or fitting installed on the bottom of the cabinet.
5. **Open Boxer-20's AC outlet box and prepare wires.** Open the AC outlet box and locate and prepare the wires for the external AC electrical connections. *Also see Paragraph 3.10 if it is also desired to wire Boxer-20's GFI convenience outlet.*
6. **Fish or route wires.** Fish or route the AC wires from the power source through the conduit to the Boxer-20 cabinet, routing the wires up through the cabinet's conduit connector and AC outlet box.
7. **Make the AC electrical wire connections.** Perform the electrical wire connections.
8. **Close the AC outlet box.** Place all wires back inside the AC outlet box, perform any needed wire management, and close up the outlet box.
9. **Proceed to Paragraph 3.11.** Proceed to Paragraph 3.11 for system power-up.

3.10 Optionally Wiring the GFI Outlet

A GFI convenience outlet is factory-installed in the cabinet near the front left corner (see Figure 21) that optionally can be used by technicians as a temporary outlet for test equipment. If the AC duplex outlet in the lower-right rear corner of the cab-

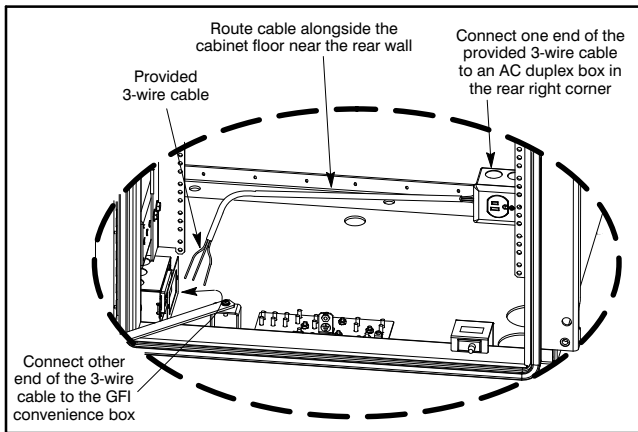

Figure 21. Installing GFI-Box-To-AC-Box Cable

inet is wired to an external AC source, AC power optionally can be provided to this GFI convenience outlet by installing the provided AC/GFI cable. Locate this standard color-coded 3-wire cable and install it between the GFI and AC duplex outlets, per National Electrical Code (NEC) rules, local codes, and company practices. Use cable ties and the holes in the flange of the L-bracket located along the bottom rear of the cabinet for routing and securing this cable.

- WARNING -

All cabinet AC/DC power wiring, cabling, and installation methods, both externally to the cabinet and installation and wiring of internal cabinet equipment, must be performed by a qualified electrician in accordance with the National Electrical Code (NEC) rules and local codes and practices.

3.11 Performing System Power-Up

Before mounting any field-provided communications equipment in the cabinet, verify all internal Boxer-20 equipment and power connections are functional. Follow the steps below to perform a Boxer-20 system power-up procedure.

1. **Verify all power and ground connections are complete.** Examine the earth ground and all power connections inside and outside the Boxer-20 cabinet and verify they are safe, secure, and complete.
2. **Turn on the external power source.** Apply the power from the external power source.
3. **Verify internal fans are operational.** Verify the internal fans are properly working by detecting air circulation directly in front of the fans.

- DESICCANT NOTE -

To prevent condensation during shipment and storage, Westell includes a desiccant pack within the Boxer-20 cabinet. Once the electronic equipment is installed and turned-up, the internal power dissipation reduces the likelihood of condensation within the cabinet. However, follow company practices for desiccant maintenance procedures to prevent internal condensation.

- LEFT CHANNEL NOTE -

Access to the controller card may be limited if one of the front-most channel mounting positions is chosen for the left channel.

3.12 Mounting Equipment Inside Boxer-20

Boxer-20 utilizes a 20-RU high and 19" wide rack with adjustable/removable rack channels. Multiple threaded holes are provided on the inside walls (best shown in Figure 7) which allow the channels to be mounted in multiple positions (can be adjusted forward or backward as needed to support Network equipment). Boxer-20's rack-hole pattern accommodates a wide variety of equipment and mounting bracket hole patterns. Always follow company practices and the guidelines below when mounting equipment inside the cabinet.

1. Verify the combined equipment height does not exceed 20 RUs.
2. Verify the combined weight of all customer-supplied equipment installed inside Boxer-20 does not exceed 130 pounds.
3. Verify any equipment to be installed in the cabinet will not extend into or past the fan guards or grills on the door of the cabinet. Slightly deeper equipment can be mounted in the lower positions of the channels (below the fans).
4. Verify each piece of equipment does not exceed the cabinet's interior width or depth.
5. Determine the best mounting location for each piece of equipment, for maximum capacity.
6. Verify the combined wattage of all equipment installed in the cabinet does not exceed 400 watts.
7. *Determine/adjust* the rack channel depth (optional). The channels are factory installed for 5" of clearance in front of the rack and 12" of clearance behind the rack. If a different clearance is required, remove the bolts from each channel (best shown in Figure 7), position the channels as needed, and re-install the bolts into each rack channel.
8. Use the bond posts provided on the ground plate as needed for bonding or grounding any cables or equipment installed inside the cabinet.

3.13 Using the Rear Access Panel

As stated in Paragraph 2.1.2.4 and as shown in Figure 6 and Figure 7, Boxer-20 contains an access panel on the rear wall to facilitate making cable connections at the inside rear of the cabinet. The panel is secured with cup-washer screws (-4HE3) or pin-in-hex screws (-4HE3G, pin-in-hex wrench provided).

3.14 Connecting Communication Cables

The types of communication cables used and their connector types (if any) vary per the application and the equipment installed inside the cabinet. To accommodate a variety of cable and connector sizes, the Boxer-20 cabinet has cable-hole knock-outs of various sizes, as shown in Table 1 and Figure 9.

1. Run the communications cables to the Boxer-20 cabinet.
2. Insert and route the cable through the desired grommet.

3. Attach the cable's connector to the appropriate connector of the targeted equipment.
4. Repeat for each cable.
5. Make any desired connections between pieces of equipment.
6. Use the bond posts and ground lugs provided on the ground plate as needed for bonding and grounding any communications cables brought into the Boxer-20 cabinet.

3.15 Making TEMP/DOOR ALARM Connections

The high temperature alarm and door alarm connections are located on the Controller Card located on the inside left wall of the cabinet. Easy pull-off/push-on Euro-connectors are provided for these installer connections. To make connections to the Euro-connectors, pull-off the Euro-connector, strip 1/4" off the end of each wire to be connected, insert the wire into the provided hole, tighten the set screw to secure the wire, repeat for each wire, then push-on the Euro-connector.

1. **Temperature Alarm.** Connect the Temperature Alarm Normally Open contact terminal to the Alarm input of the field-provided alarm monitoring device. Connect the common contact terminal to the common input of the alarm monitoring device. For reference, the Normally Open Temperature Alarm thermostat contact closes when the internal cabinet temperature exceeds 65° C.
2. **Door Alarm.** Connect the Door Alarm Normally Open Door Alarm contact terminal to the Alarm input of the alarm monitoring device. Connect the common contact terminal to common input of the alarm monitoring device. For reference the Normally Open contact closes when either the Network or Customer door is opened.

- DEACTIVATING THE DOOR ALARM -

The door alarm sensor can be temporarily disabled during equipment installation or maintenance by gently pulling out the cylindrical-shaped switch actuator until it clicks. Closing the door automatically resets and enables the sensor. To manually enable the door alarm sensor, gently push the switch actuator back in until a click is heard.

3.16 Optioning Installed Equipment

Make all option settings on the installed equipment per equipment manufacturer instructions and company practices. If needed, open the convenient rear access panel (shown in Figure 7) to access the rear of the equipment.

3.17 Performing Cabinet Housekeeping

Verify all equipment is secure, verify all wires and cables are neatly organized and managed, verify all bonding and grounding connections are made at the ground plate, and verify no equipment, tie-downs, cables, or wires will interfere with the closing of the door. Clean up the installation site per company practice.

3.18 Closing and Locking the Cabinet

Upon completion, the installer should close and lock the cabinet by firmly pressing on the door, turning the swing handle to the vertical position, then pressing the handle down to seat it. **When closing and locking the door, the door must be pushed fully**

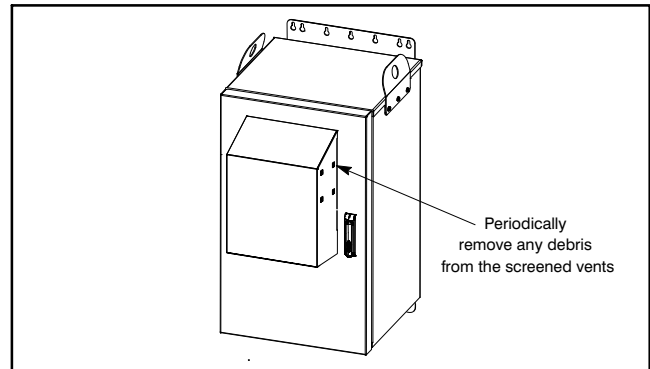

Figure 22. Clean the Air Intake/Exhaust Screened Holes

closed before engaging the swing handle, or damage to the locking mechanism may result. Secure the door by tightening the cup-washer screw with a can wrench or 216 tool (for the -4HE3 model) or the pin-in-hex screw with the provided hex wrench (for the -4HE3G model), and optionally lock the door via the hasp in the door handle which accepts a field-provided lock or padlock (customer supplied).

4. MAINTENANCE

The Westell® Boxer® components are maintenance-free, however, please note the following item.

- At least once every six months, periodic inspections should be performed on the Boxer-20 cabinet to remove any debris from the fan cover's screened vents (Figure 22). This facilitates proper operation of the cabinet and allows unobstructed air flow.

5. SERVICE AND REPAIRS

Replacing parts is the only recommended type of field repair for the Westell® Boxer® cabinet. The list below contains the only Boxer parts which may be ordered and field-replaced (see Part 6 for a telephone number, Table 4 for part numbers, and Paragraph 7.2 for the return procedure). See Paragraph 5.1 through 5.4 for detailed steps to remove and replace these parts.

Field-replaceable parts:

- Controller Card
- Outside Air Fans
- Inside Air Fans
- Door Open Sensor Switch Assembly

- CAUTION -

To avoid electrical shock, turn off any DC or AC power feeds to the panel before removing or replacing the controller card.

5.1 Replacing the Controller Card

The Controller Card cannot be field *repaired*. Should a problem be suspected with the card, it must be removed and returned to Westell for service, then re-installed or *replaced*. Follow the steps below to replace the controller card.

1. **Disconnect power.** Disconnect power to the card by removing the power Euro-connector block (labeled “-V” and “+V”). Pull the connector toward the cabinet front.
2. **Remove all connectors.** Disconnect all other wire connections in the card by simply pulling off each Euro-connector in the controller card (on the card’s left and bottom edges, see Figure 20) in similar fashion, and labelling each connector as it is removed, to facilitate later re-connection with the replacement card. It is not necessary to remove any wires from the connectors (unless a fan is suspected of being faulty and is also being replaced).
3. **Remove card.** Remove the old card by removing the hardware that secures the card to the cabinet wall, then pulling the card off the studs.
4. **Install new card.** Replace the old card with the new card, ordered and received from Westell. Be sure the card labeling is visible and not upside down, align the mounting holes in the card with the posts on the cabinet wall, then tighten the nuts onto the studs to secure the card. Re-insert or snap-on all connectors in their proper positions in the card, connecting the power connector block last.
5. **Test.** Verify the alarms work. Verify the fans are working properly by pressing the fan test button (see bottom of Figure 20 for location).

- CAUTION -

To avoid electrical shock, turn off any DC or AC power feeds to the controller before beginning this procedure.

5.2 Replacing the “Outside Air” Fans

Fans cannot be field *repaired* but are field replaceable. Should a problem be suspected with an “outside air” fan, remove the fan and return it to Westell for service, then replace it. See Table 4 for ordering information. To remove and replace an “outside air” fan, proceed with the following instructions.

1. **Open the cabinet.** Open the cabinet door by loosening the door lock with a can wrench or 216 tool (for the -4HE3 model) or with the special provided pin-in-hex wrench (for the -4HE3G model), then turning the door handle (see Figure 4).
2. **Remove cover.** Remove the heat exchanger compartment cover by first loosening the Phillips screw (near the center of the interior surface of the door, see Figure 3) with a Phillips screwdriver, then lifting the cover off the two posts that secure it, at the exterior top of the cabinet door.
3. **Remove fuse.** Remove the 5A fan fuse from the controller card (see Figure 12 or Figure 20 for fuse location).
4. **Disconnect fan power.** Disconnect the FAN A connector at the controller card.
5. **Remove wires from connector.** Remove both wire sets from the now disconnected Fan A Euro-connector by unscrewing the two set screws in the connector, pull out the loosened wires. Note that two same-colored wires, one from each fan, were twisted together to form a single wire for each wire-port connection.

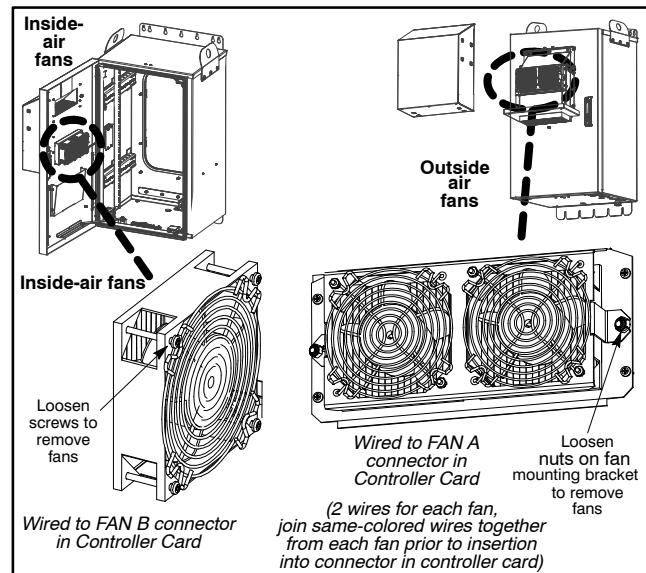

Figure 23. Field Replacement of Fans

6. **Replace connector.** Insert the empty connector back into the controller card.
7. **Note fan cable routing and free the cable wires.** Make a note of the fan cable wire-routing between the fan mounting location (through the hole in the door) and the controller card, for reference when installing the replacement fans/cable wires. Gently free or loosen the wires from any cable management devices.
8. **Pull wires through door.** Pull the disconnected wires to the exterior fan side through the hole/fitting in the door.
9. **Verify fan is off.** Visually check to ensure that the fan blades are NOT rotating.
10. **Remove fan mounting bracket.** Loosen and remove the two hex nuts on either side of the bracket that secures the exterior fans. Remove the bracket.
11. **Dismount fan(s).** Remove/lift off the old fan(s).
12. **Re-mount bracket.** Temporarily re-mount the bracket and thread the nuts back onto their posts to secure the bracket.
13. **Return fans.** Return the fan(s) to Westell for repair or replacement (see Paragraph 7.2).
14. **Install replacement fan(s).** Remove the fan mounting bracket. Mount the replacement fan(s) back on the outside of the door by hanging it/them from the mounting posts. Align the holes in the heat exchanger wall with the holes in the fans and the fan mounting bracket, and re-insert and thread the screws through the aligned hole sets. Verify the fan cable wires exit at the top of the fan assembly, that they are/will not be pinched under the fan, and that they face or route toward the cable access hole in the door at the left side of the heat exchanger unit. Verify the fans are oriented and mounted such that the air flow direction will be out of the cabinet. (Re)route the fan wires toward the controller card, noting and using the cable

routing from Step 7 above. Route, manage and secure the wires (and any slack) so they are neat and will not be pinched.

15. **Connect fan wires to “FAN A” Euro-connector.** Remove the empty FAN A connector from the controller card. Twist and join together the stripped ends of the same-colored wires from each fan (i.e., twist a red wire end from one internal fan with a red wire end from the second internal fan), to make a conjoined single wire. Insert this conjoined wire into its proper wire port hole in the connector (e.g., insert the RED wire(s) into the port labeled “RED”) and tighten the port’s set screw to secure the wire. Repeat for the other/black conjoined wire. Read the note below prior to securing the fan(s) and making wire connections.

- FAN WIRING IN EURO-CONNECTOR NOTE -

One euro-connector serves two fans: there is one connector for the two external air fans (connector labeled “FAN A”) and one connector for the two internal air fans (“FAN B”). Each fan has a black wire and a red wire. When wiring a new or replacement fan, the same colored wire from each fan should first be twisted together as a single wire unit prior to insertion into its proper termination hole in the connector.

16. **Apply power; re-install FAN A Euro-connector and fuse.** Keeping fingers, hair, clothing, wires, tools, etc. away from the fans, insert the FAN A Euro-connector and the 5A fuse back into their proper positions in the controller card. Verify the connector is *not* upside-down (i.e., BLK wires terminating at position labeled BLK [up], RED wires at position labeled RED [down]).
17. **Verify power is present, and test.** Verify the fans are operational and working properly. Use the fan test button if/as needed.

5.3 Replacing the “Inside Air” Fans

Fans cannot be field *repaired*. Should a problem be suspected with an “inside air” fan, remove the fan and return it to Westell for service, then *replace* it. See Table 4 for ordering information. To remove and replace an “inside air” fan, proceed with the following instructions.

- CAUTION -

To avoid electrical shock, turn off any DC or AC power feeds to the controller before beginning this procedure.

1. **Open the cabinet.** Open the cabinet door by loosening the door lock with a can wrench or 216 tool (for the -4HE3 model) or with the special provided pin-in-hex wrench (for the -4HE3G model only), then turning the door handle (see Figure 4).
2. **Remove fuse.** Remove the 5A fan fuse from the controller card (see Figure 12 or Figure 20 for fuse location).
3. **Disconnect fan power.** Disconnect the FAN B connector (for the inside fans) at the controller card.
4. **Remove wires from connector.** Remove both wire sets from the now disconnected Fan B Euro-connector by unscrew-

ing the two set screws in the connector, pull out the loosened wires. Note that two same-colored wires, one from each fan, were twisted together to form a single wire for each wire-port connection.

5. **Replace connector.** Insert the empty connector back into its position on the controller card.
6. **Verify fan is off.** Visually check to ensure that the fan blades are NOT rotating.
7. **Note fan cable routing and free the cable wires.** Make a note of the fan cable wire-routing between the fan mounting location and the controller card, for reference when installing the replacement fans/cable wires. Gently free or loosen the wires from any cable management devices.
8. **Remove fan mounting screws.** Remove the screws that secure the fan(s) to the inside of the cabinet door.
9. **Dismount fan(s).** Remove/lift off the old fan(s).
10. **Store screws.** Re-install the screws into their mounting holes.
11. **Return fans.** Return the fan(s) to Westell for repair or replacement (see Paragraph 7.2).
12. **Install replacement fan(s).** Mount the replacement fan(s) back on the mounting bracket on the inside of the door by removing the stored screws, aligning the holes in the mounting bracket, fans, and fan guards, and re-inserting the screws in the aligned hole sets. Verify the fan cable wires are/will not be pinched and face toward the inside of the cabinet. Verify the fans are oriented and mounted such that the air flow direction will be into the cabinet. Re-route the fan wires toward the controller card, noting and using the cable routing from Step 7 above. Route, manage and secure the wires (and any slack) so they are neat and will not be pinched.
13. **Connect fan wires to “FAN B” Euro-connector.** Remove the FAN B connector from the controller card. Twist and join together the stripped ends of the same-colored wires from each fan (i.e., twist a red wire end from one internal fan with a red wire end from the second internal fan), to make a conjoined single wire. Insert this conjoined wire into its proper wire port hole in the connector (e.g., insert the RED wire(s) into the port labeled “RED”) and tighten the port’s set screw to secure the wire. Repeat for the other/black conjoined wire. Read the note below prior to securing the fan(s) and making wire connections.

- FAN WIRING IN EURO-CONNECTOR NOTE -

One euro-connector serves two fans: there is one connector for the two external air fans (connector labeled “FAN A”) and one connector for the two internal air fans (“FAN B”). Each fan has a black wire and a red wire. When wiring a new or replacement fan, the same colored wire from each fan (same type fan) should first be twisted together as a single wire unit prior to insertion into its proper termination hole in the connector.

14. **Apply power; re-install FAN B Euro-connector and fuse.** Keeping fingers, hair, clothing, wires, tools, etc. away from the fans, insert the FAN B Euro-connector and the 5A fuse back into their proper positions in the controller card.

Verify the connector is *not* upside-down (i.e., BLK wires terminating at position labeled BLK [up], RED wires at position labeled RED [down]).

15. **Verify power is present, and test.** Verify the fans are operational and working properly. Use the fan test button if/as needed.

5.4 Replacing the Door Sensor Switch

The door sensor switch cannot be field repaired. Should a problem be suspected with the door switch, remove the switch and either return it to Westell for service or order a new switch, then replace the faulty switch. To remove and replace the door sensor switch, proceed with the following instructions.

- CAUTION -

To avoid electrical shock, turn off any DC or AC power feeds to the controller before beginning this procedure.

1. **Open the cabinet.** Open the cabinet door by loosening the door lock with a can wrench or 216 tool (for the -4HE3 model) or with the special provided pin-in-hex wrench (for the -4HE3G model only), then turning the door handle (see Figure 4).
 2. **Disconnect door switch power.** Pull out and remove the "DOOR SWITCH-2" Euro-connector at the right side of the controller card or remove the 5A fuse to disconnect power at the door switch.
 3. **Remove nuts that secure the door switch mounting bracket.** The door sensor switch is mounted on a bracket located at the front, right, bottom corner of the cabinet. Remove the nuts that secure the bracket to the threaded posts in the lower, right front corner of the open cabinet (Figure 9).
 4. **Separate the switch from the bracket and disconnect wires.** Lift the door switch assembly and gently pull the door sensor switch away from the mounting bracket (snap it out), to access the door switch assembly's cable wires. Carefully pull off or disconnect the red and black female disconnect wires from their terminals on the switch, one at a time, labelling each and making a note of which colored wire connector mated with which switch terminal, for easy reconnection to the new, replacement, switch assembly.
 5. **Remove the door sensor switch.** Remove (and return to Westell or discard) the old door sensor switch.
 6. **Install the new door sensor switch.** Reverse the steps above to install the replacement door sensor switch (route the door switch cable wires through the front cut-out hole in the mounting bracket [from the rear to the front], attach the cable wire ends [disconnect terminals] to their proper terminals at the back of the replacement switch [see bullets below], mount the switch in the bracket by inserting it rear-first into and through the bracket's front rectangular hole cut-out and snap it into place).
- Verify the two wire/connectors are routed so that they can *easily* reach the back of the door sensor (no tension).
 - Route both wires, from the left to the right, under the top flange of the door switch mounting bracket, then allow sufficient slack in the wire that will connect to the right terminal of the switch such that it can loop past then back toward the switch so as to properly mate with the switch terminal angled to the right. Manage and secure the cable wire slack per company practice.
 - Verify that the door alarm cable's black wire connects to the door switch terminal lug labelled "COM," and that the cable's red wire connects to the terminal lug labelled "NC" (or as labeled in Step 4 above).
7. **Secure door switch mounting bracket to the cabinet floor.** Attach the door switch mounting bracket back onto the cabinet by aligning the bracket's mounting holes with the threaded posts in the lower, right front corner of the cabinet, setting the bracket down over the posts, and threading the mounting hex nuts back onto the posts until tight.
 8. **Apply power and test.** Re-attach the previously removed door switch Euro connector and/or the 5A fuse into the controller card to apply power. Verify that the switch is working properly. To disable the door alarm, pull out or forward on the switch's cylindrical-shaped actuator; either press back on it or close the door to reset/re-enable it.

6. CUSTOMER & TECHNICAL SERVICES

6.1 Customer Service & Technical Assistance

If technical or customer assistance is required, contact Westell by calling or using one of the following options:

Voice: (800) 377-8766
email: global_support@westell.com

For additional information about Westell, visit the Westell World Wide Web site at <http://www.Westell.com>.

6.2 Part Numbers

This equipment is identified by a product number (A90-BXM2019-4HE3), which consists of three parts: the issue letter of the equipment (A), the assembly type (90), and the specific model number (BXM2019-4HE3). Each time a change is made to the product which changes the form, fit, or function of the product, the issue letter is incremented or advanced by one. Be sure to indicate the issue level as well as the model number when making inquiries about the equipment.

7. WARRANTY & RETURNS

7.1 Warranty

Westell warrants this product to be free of defects at the time of shipment. Westell also warrants this product to be fully functional for the time period specified by the terms and conditions governing the sale of the product. Any attempt to repair or modify the equipment by anyone other than an authorized Westell representative will void the warranty.

7.2 Return and Replacement Policy

Westell will repair or replace any defective Westell equipment without cost during the warranty period if the unit is defective

When re-attaching the door switch cable's two wires to the new door switch sensor assembly, verify/perform the following:

for any reason other than abuse, improper use, or improper installation. Before returning the defective equipment, first request a Return Material Authorization (RMA) number from Westell. Once an RMA number is obtained, return the defective unit, freight prepaid, and a brief problem description to:

Voice: (630) 375-4457
email: rgmdept@westell.com

Replacements will be shipped in the fastest manner consistent with the urgency of the situation. Westell will continue to repair or replace faulty equipment beyond the warranty period for a nominal charge. Contact Westell for details.

Physical Feature	U.S.	Metric
Height (cabinet only)	40.01 in.	101.63 cm
Height (including lift ears & mounting brackets)	46.95 in.	119.25 cm
Height (between top & bottom mounting holes)	43.675 in.	110.93 cm
Width (cabinet only)	24.00 in.	60.96 cm
Width (including lift ears & hardware)	25.12 in.	63.80 cm
Width (interior)	23.75 in.	60.33 cm
Width (interior, between channels)	17.85 in.	45.34 cm
Width (between left/right rack channel mounting holes)	18.32 in.	46.53 cm
Depth (from door front to rear panel)	20.60 in.	52.32 cm
Depth (overall, including cover & brackets)	28.82 in.	73.20 cm
Depth (including cover, without brackets)	28.10 in.	71.37 cm
Depth (door open 90°)	43.50 in.	110.5 cm
Depth (internal)	17.50 in.	44.45 cm
Weight (cabinet, approx.)	110 lbs.	49.90 kg
Weight Load (Max.)	130 lbs.	58.9 kg
Operating Temp. (including solar loading)	-40° to 115°F	-40° to 46°C
Humidity	0 to 95% (non-condensing)	
Mounting*	H-Frame, wall, pole, pad	

* Boxer can be pad-mounted when mounted and mated with an optional battery box, and pole mounted with the pole mount kit (see Table 4).

Table 3. Boxer-20 Cabinet Physical Specifications

8. SPECIFICATIONS

8.1 Regulatory/Agency Specifications

The Boxer-20 cabinet is compliant with the following regulatory, safety or environmental specifications or requirements:

- NEMA 4 (both models)
- GR-487 Issue 4 compliant (-4HE3G model)

8.2 Ordering Specifications

To order units, call the telephone number shown in Paragraph 6.1 and please specify a specific model number shown in Table 4.

8.3 Electrical and Physical Specifications

The Boxer electrical and signalling specifications are listed below, and the physical specifications are shown in Table 3.

Power Specification

- A. Fan power: -56 W typical, 84 W max when powered from a +24V or -48V source

Controller Card Specifications

- B. Provisions for +24V or -48VDC inputs to power the fans
- C. 5 Amp GMT Fan fuse
- D. Provisions for door open contacts (Normally Open)
- E. **Heat exchanger fans.** Turn on at 35° C (95° F), turn off at 25° C (77° F)

Cooling

- F. 400W Heat exchanger

Boxer Ordering Information				
A90-BXM2019-4HE3 & A90-BXM2019-4HE3G		Westell® Boxer® cabinet, 400W, +24 or -48VDC heat exchanger cooling, temperature-controlled, controller card, single full-size door, locking rear access panel, built-in 20-RU 19" rack, door switch, numerous knock-outs. 4HE3 uses cup-washer screws in the front door and rear panel, the -4HE3G uses pin-in-hex screws. -4HE3G is GR-487 Iss. 4 compliant.		
Other Boxer Family Outdoor Cabinets				
Series	Description	Cooling	Power	Part Number
Boxer 5 <i>(5-RU 19" tall rack)</i>	Main Cabinet	Passive cooling	N/A	A90-BXM05V19-NMT
		150W fan-cooled, always-on	-48VDC	A90-BXM05V19-NAF
		200W heat exchanger, always-on	-48VDC	A90-BXM05V19-2HE
		200W heat exchanger, temp-controlled	+24 or -48VDC	A90-BXM05V19-2HE3
		Same as -2HE3 but GR-487 Issue 4 complaint	+24 or -48VDC	A90-BXM05V19-2HE3G
Boxer 10 <i>(10-RU 19" wide rack)</i>	Main Cabinet	Passive cooling	N/A	A90-BXM1019-NMT
		400W heat exchanger, always-on	-48VDC	A90-BXM1019-NHE
		400W heat exchanger, temp-controlled	+24 or -48VDC	A90-BXM1019-NHE3
		Same as -NHE3 but also GR-487 Iss. 4 compliant	+24 or -48VDC	A90-BXM1019-NHE3G
		600W fan-cooled, always-on, customer access door	-48VDC	A90-BXM1019-CAF
	Main Cabinet+SideCar+Battery Box	400W heat exchanger, always-on	-48VDC	A90-BXSC1019-4H
Boxer 16 <i>(16-RU 19" wide rack)</i>	Main Cabinet	400W heat exchanger, always-on	-48VDC	A90-BXM1619-4HE
		700W heat exchanger, temp-controlled	-48VDC	A90-BXM1619-7HE
		Same as the -7HE but GR-487 Iss. 4 complaint	-48VDC	A90-BXM1619-7HEG
		4K BTU air conditioner, temp-controlled	120VAC	A90-BXM1619-4KAC
	Main Cabinet+SideCar+Battery Box	400W heat exchanger, always-on	-48VDC	A90-BXSC1619-4H
Boxer 20 <i>(20-RU 19" wide rack)</i>	Main Cabinet	400W heat exchanger, always-on	-48VDC	A90-BXM2019-4HE
		400W heat exchanger, temp-controlled	+24 or -48VDC	A90-BXM2019-4HE3
		Same as the -4HE but GR-487 Issue 4 complaint	+24 or -48VDC	A90-BXM2019-4HE3G
	Main Cabinet+SideCar+Battery Box	400W heat exchanger, always-on	-48VDC	A90-BXSC2019-4H
Boxer 30 <i>(30-RU 19" wide rack)</i>	Main Cabinet	1000W heat exchanger, temp-controlled	-48VDC	A90-BXM3019-10HE
	Main Cabinet+SideCar+Battery Box	1000W heat exchanger, temp-controlled	-48VDC	A90-BXSC3019-10H

* In the Boxer 5 cabinet, the 19" wide rack is vertical (rotated 90 degrees, with channels at top and bottom).

Table 4. Boxer Cabinet Ordering Information

Boxer Battery Boxes, Accessories, and Options							
Type	Part Number	Description	Supported Models				
			Boxer 5	Boxer 10	Boxer 16	Boxer 20	Boxer 30
Battery Boxes & Skirts	A90-BXB05V-A	Battery box standard	✓				
	A90-BXB19-A			✓	✓	✓	✓
	A90-BXB19-B	Battery box with heater pad		✓	✓	✓	✓
	A90-BXB19-D	Battery box wide for Boxer with SideCar		✓	✓	✓	✓
	A90-BXS19-14	Skirt box for boxer, 14" high		✓	✓	✓	✓
Accessories	A90-BXA-HP01	Battery heater pad		✓	✓	✓	✓
	A90-BXA-PM02	Pole mount kit: main cabinet		✓	✓	✓	
	A90-BXA05V-PM2	Pole mount kit: main cabinet only	✓				
	A90-BXA05V-PM3	Pole mount kit: main cabinet + battery box	✓				
	A90-BXA-PM03	Pole mount kit: main cabinet + standard battery box		✓			
	A90-BXA-PM05	Pole mount kit: main cab. + standard & wide battery box			✓	✓	✓
	A90-BXA-WH01	Wall/H-frame mount kit: main cab. + std & wide battery box		✓	✓	✓	✓
	A90-BXA05V-WH1	Wall mount kit: main cabinet + battery box	✓				
	A90-BXA-PT1	Pad mount template: standard battery box		✓	✓	✓	✓
	A90-BXA-PT2	Pad mount template: wide battery box		✓	✓	✓	✓
A90-BXA-CK01	Coupler kit (2) 1/2", (2) 3/4", (4) 2"	✓	✓	✓	✓	✓	

Table 5. Boxer Orderable Options and Accessories

Appendix A – Product Views

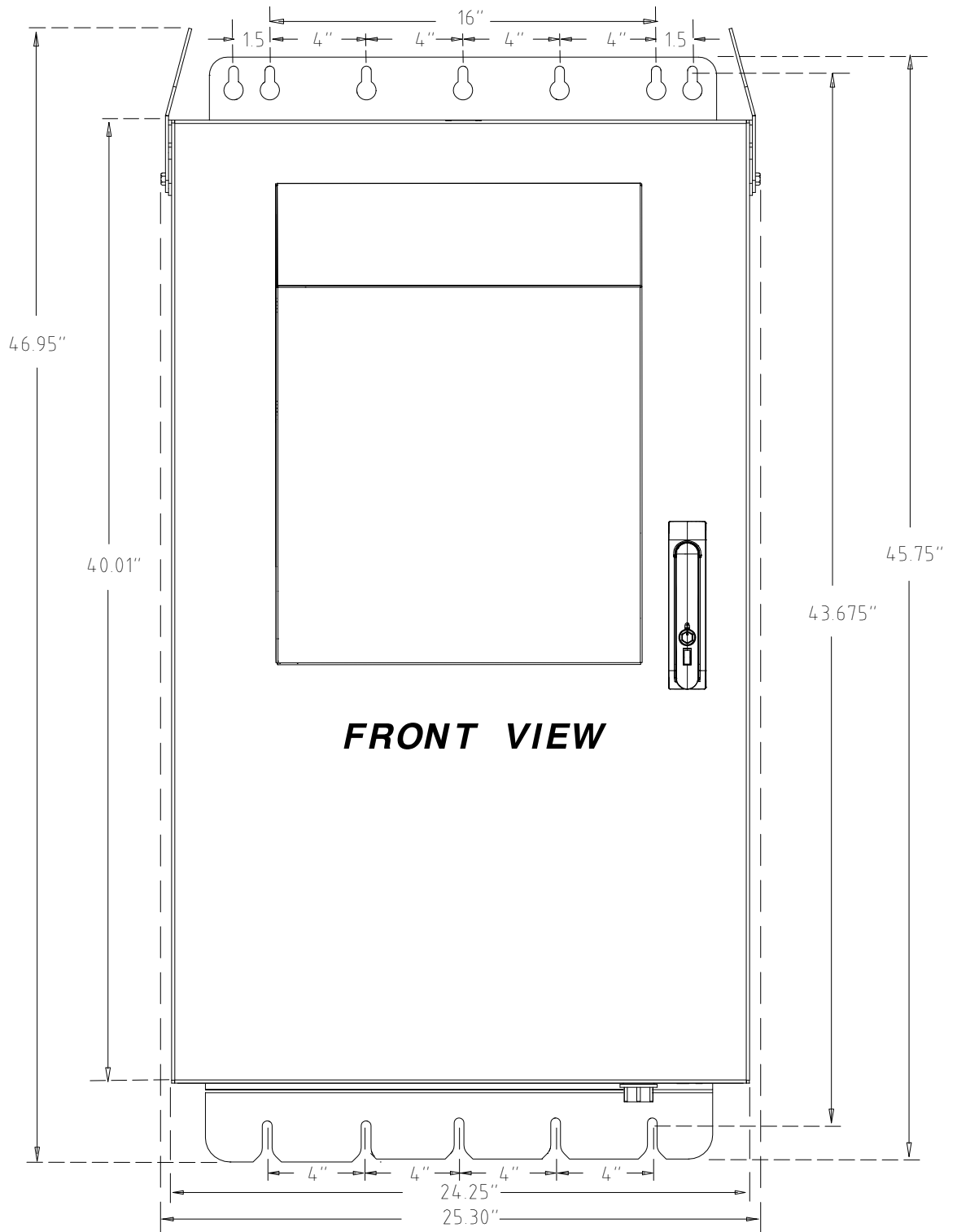

Figure 24. Front Exterior View of Boxer-20 Cabinet

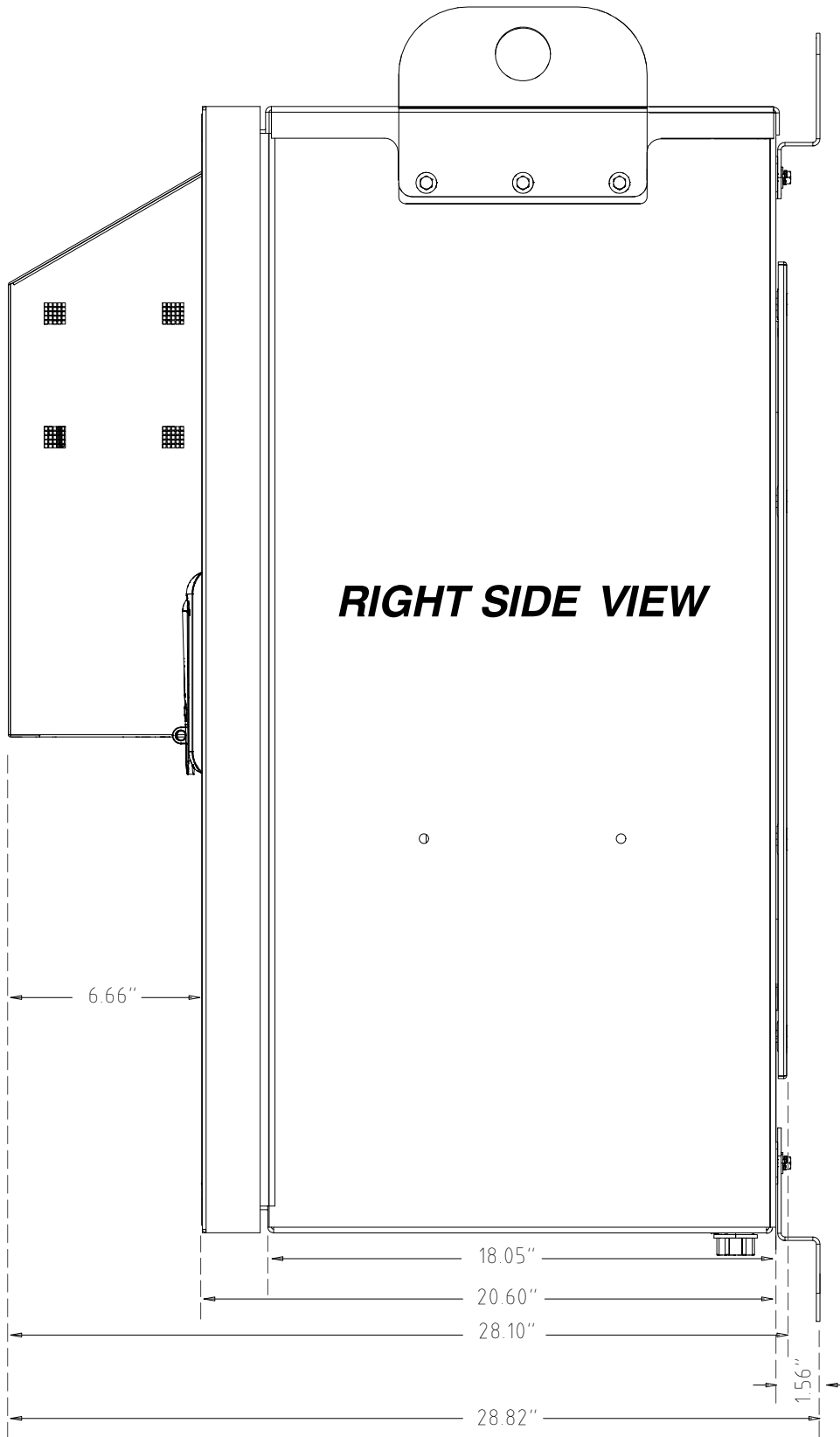

Figure 25. Right Side Exterior View of Boxer-20 Cabinet